



Astronomical Scaling

Patrick Groeneveld
Montreux, 20 April 2023

From Antwerp to Montreux

Train 🚂



Car 🚗

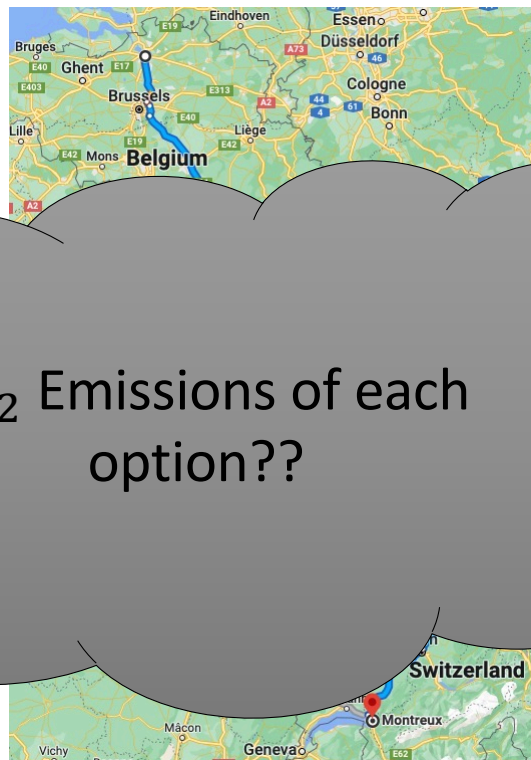

Airplane ✈️

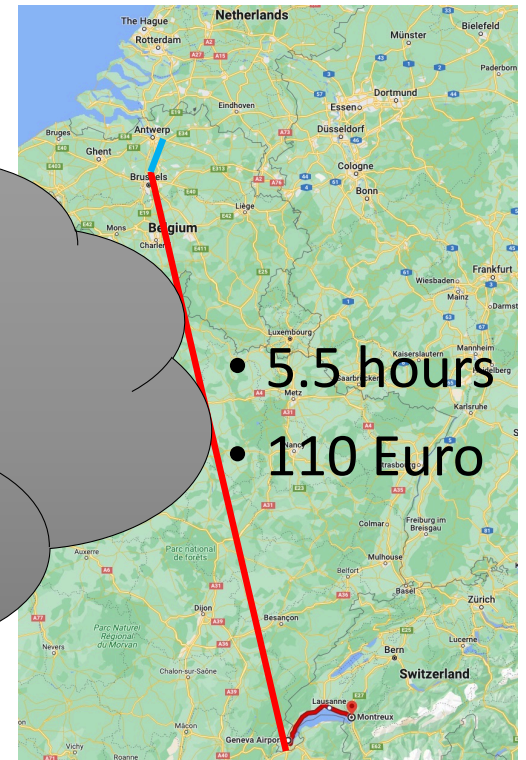

CO₂ Emissions of each option??

Energy Efficiency

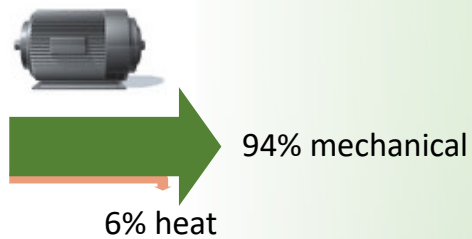
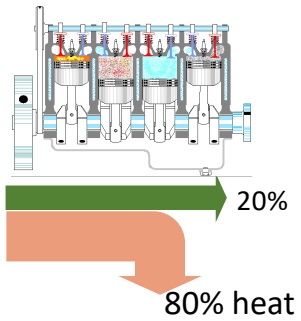
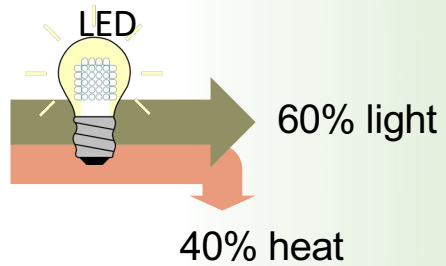
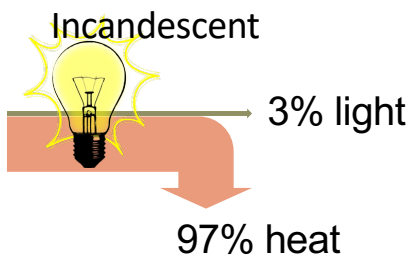

Energy Efficiency of Transportation

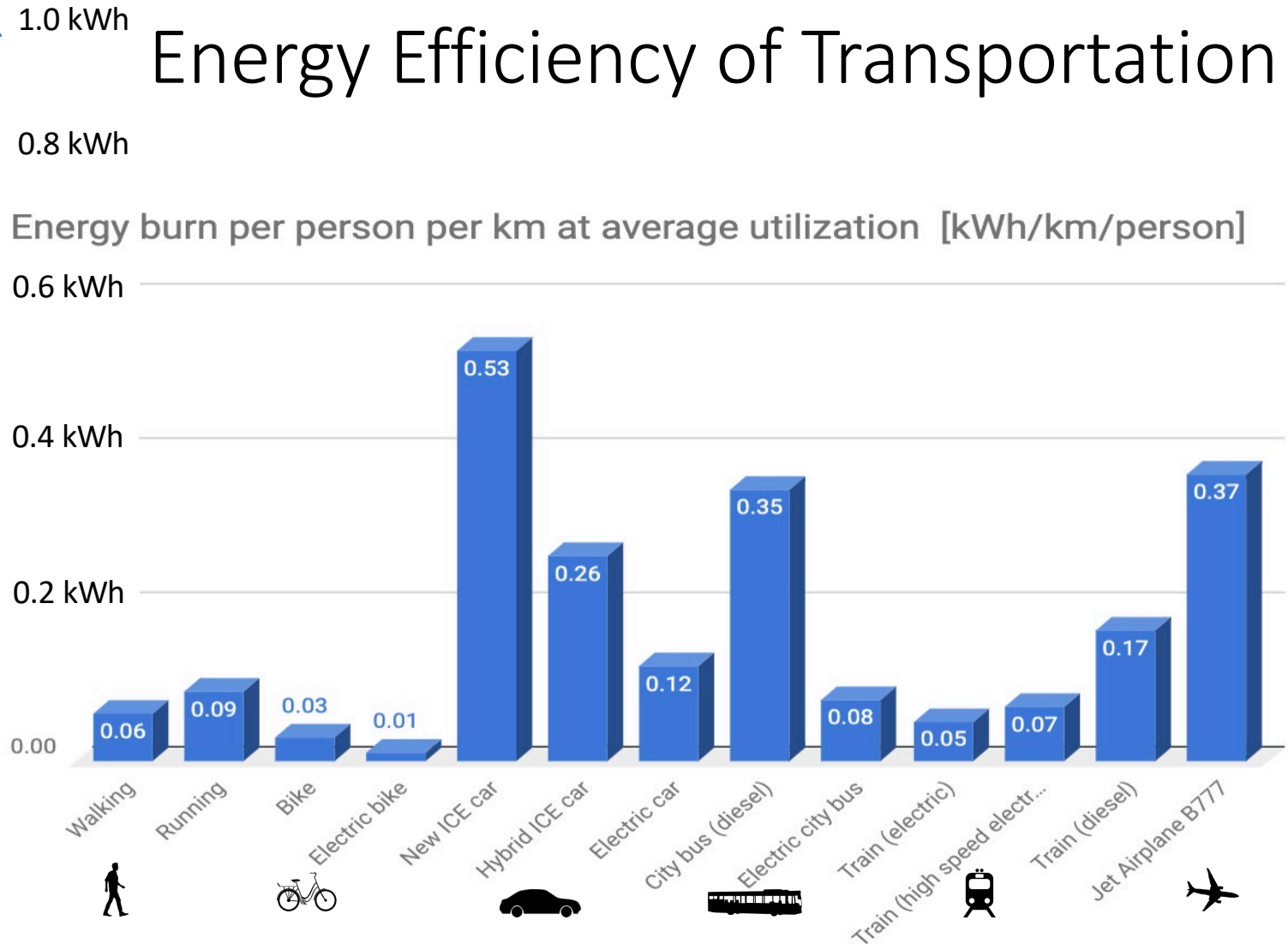

CO₂ GHG Emissions per Kilometer

Energy per km

Energy burn per person per km at average utilization [kWh/km/person]

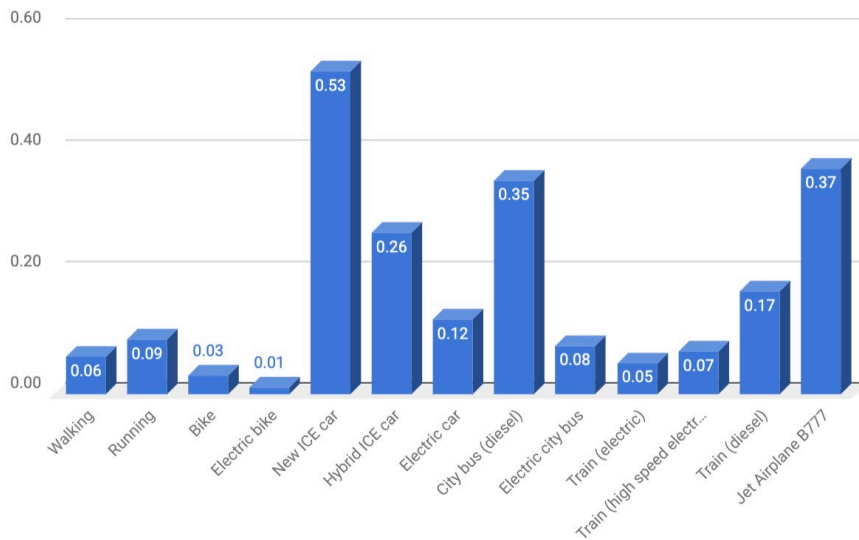

CO₂ GHG Emissions per km

Emissions per person per km at average utilization, USA [gram CO₂]

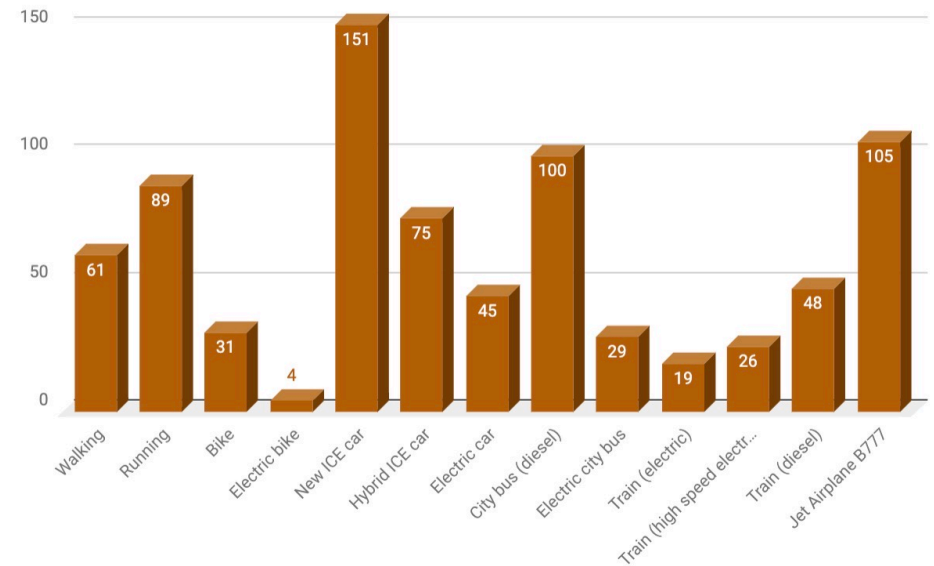

Effects of Cleaner Generation

370 g CO₂/kWh (e.g. USA, Germany)
Diet with meat and dairy

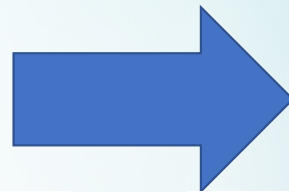

60 g CO₂/kWh (e.g. France, Switzerland)
Diet light on meat and dairy

Emissions per person per km at average utilization, USA [gram CO₂]

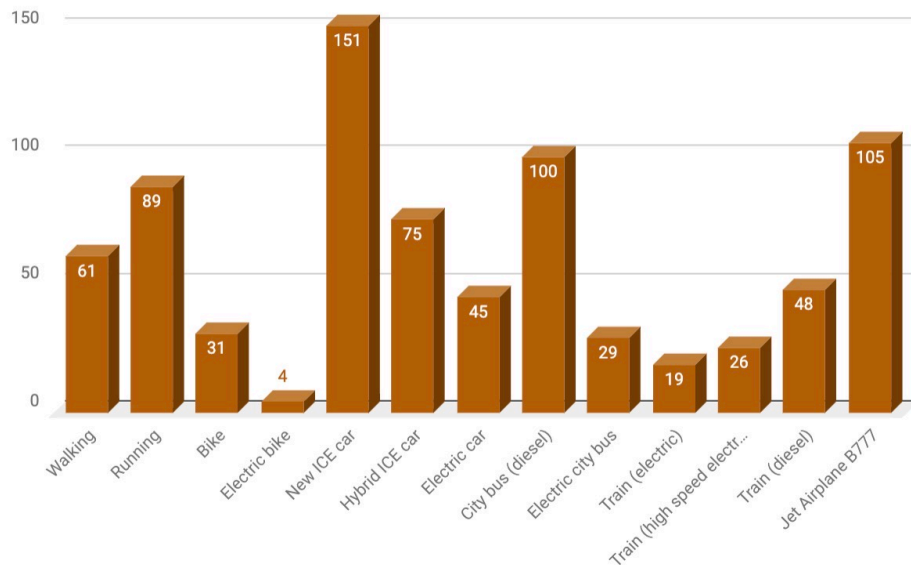

Emissions per person per km at average utilization [gram CO₂]

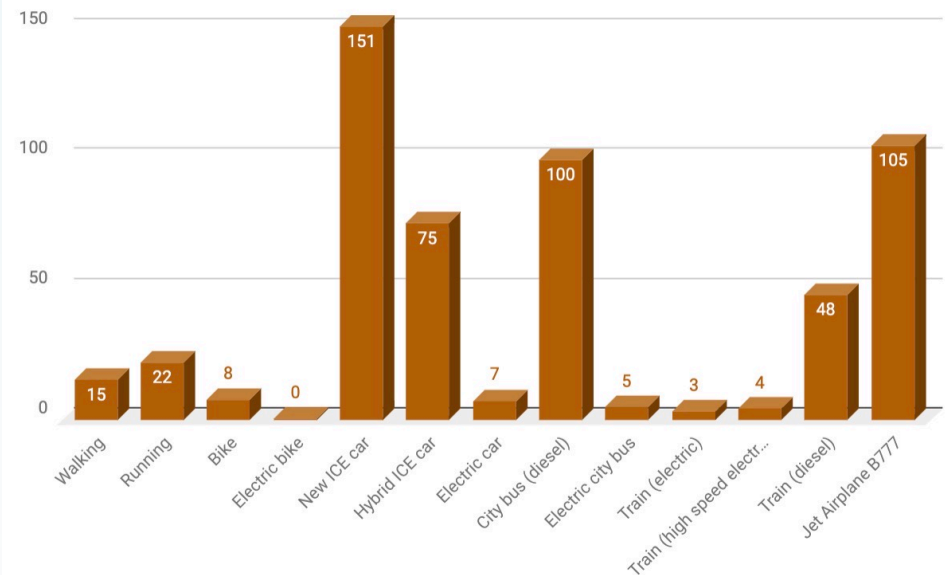

CO₂ Footprint for Travel from Antwerp to Montreux

Train 🚂



Car 🚗

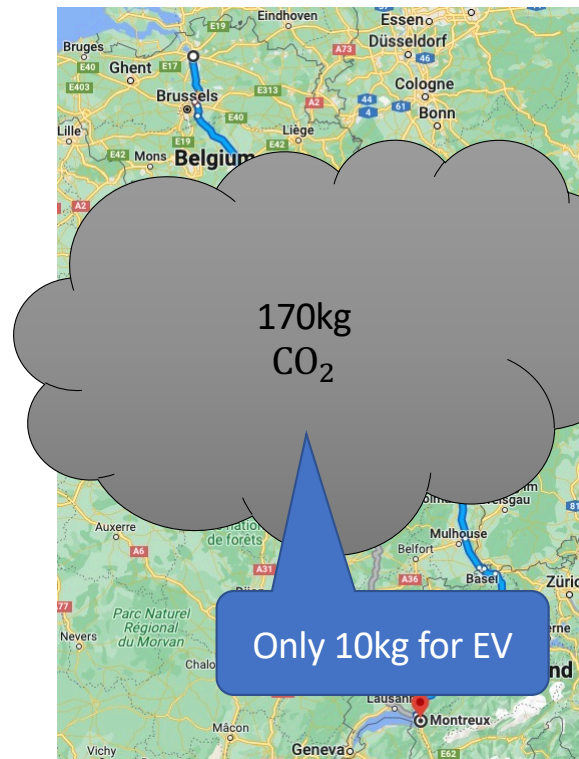

Airplane ✈️

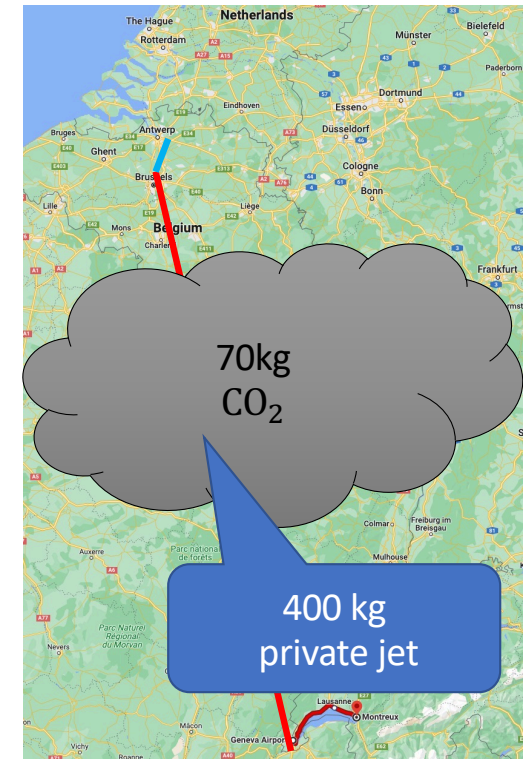

What Happens to Efficiency Gains?



More Efficient over time, but...

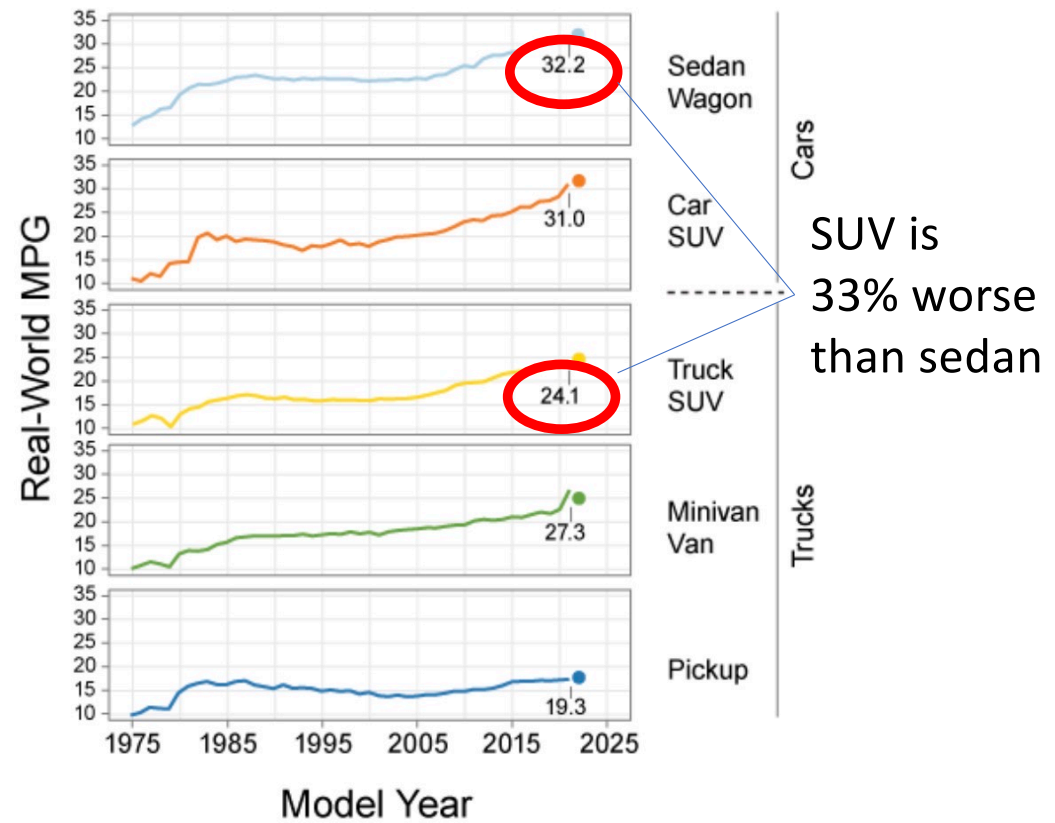

Source: EPA

ICE Porsche SUV vs ICE VW Golf sedan

- **2X worse** efficiency (km/l or MPG)
- 1.6X heavier
- 4X more expensive

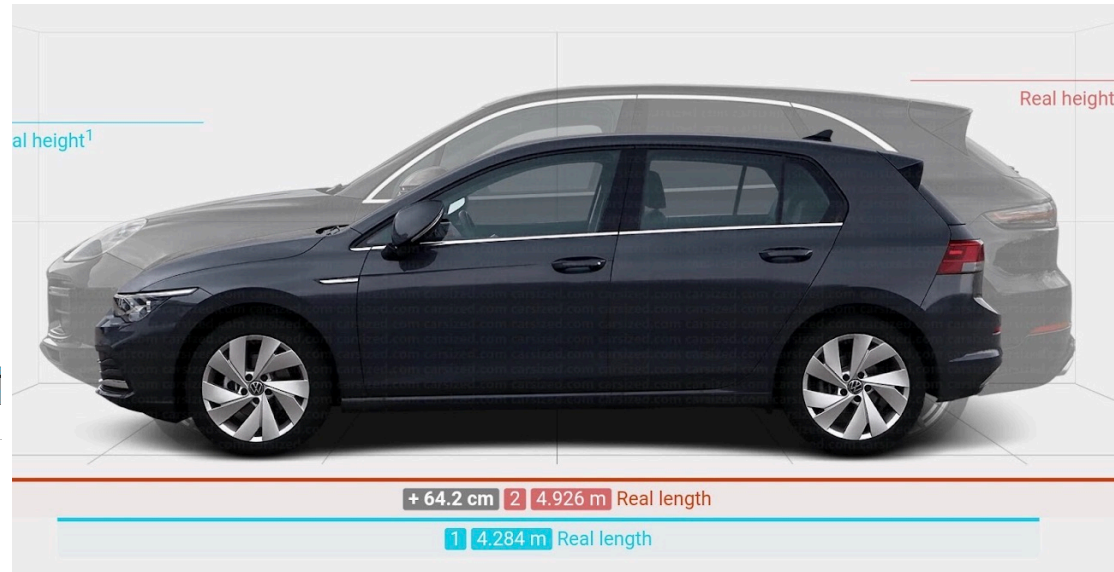
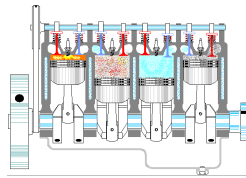

Electric Tesla Model Y SUV vs Electric Tesla Model 3 sedan

- **1.1X worse** efficiency (km/kwh)
- 1.15X heavier
- 1.07X more expensive

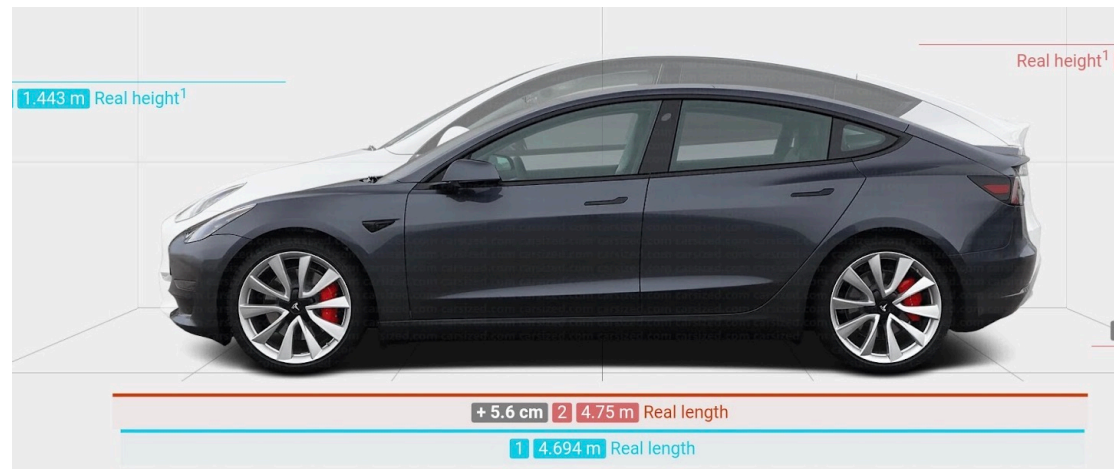

Jevons Paradox (1865)

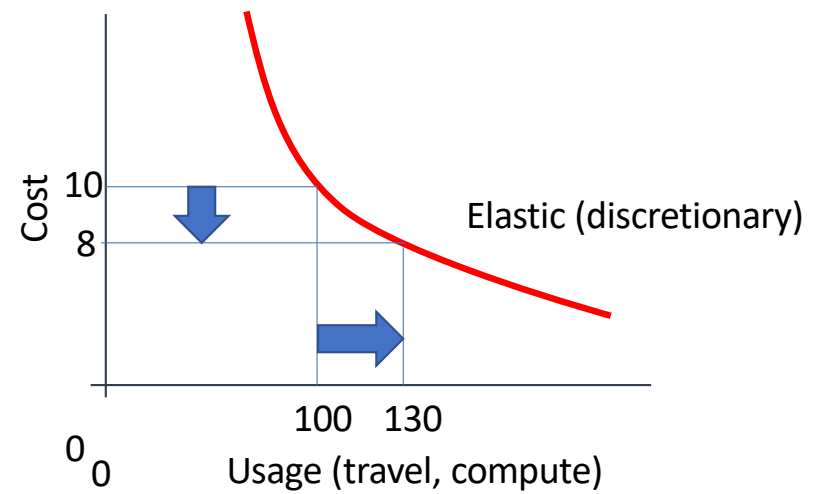
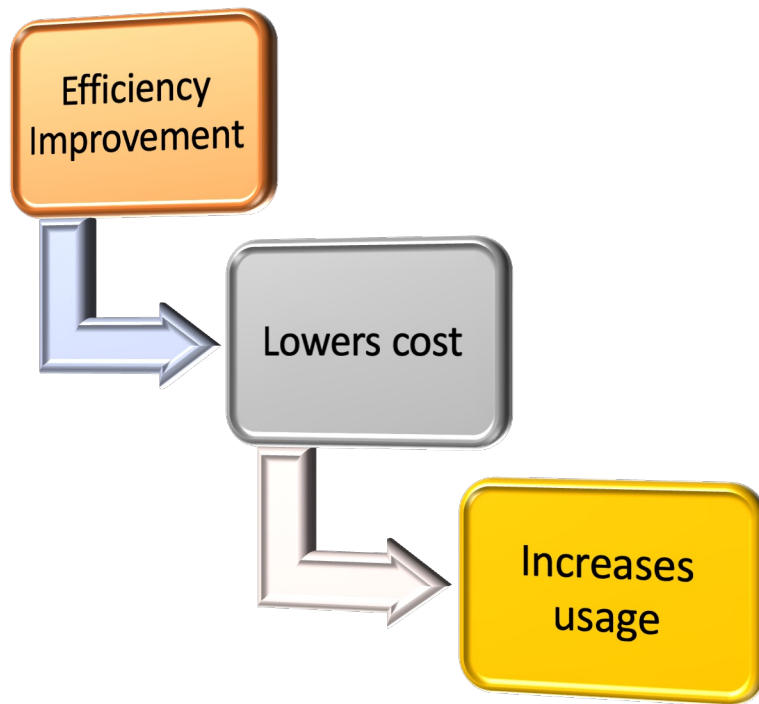

Moore's Law *avant la lettre*

Apollo Guidance Computer

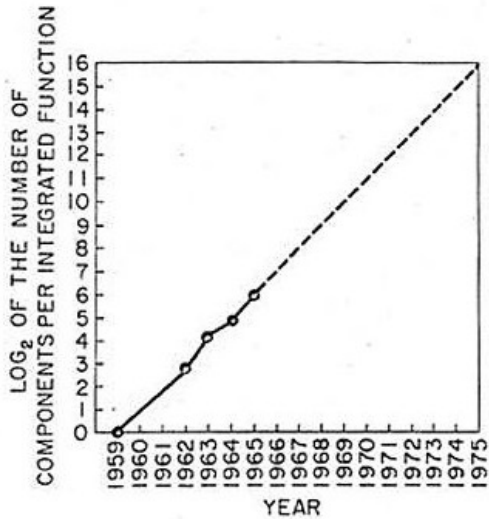
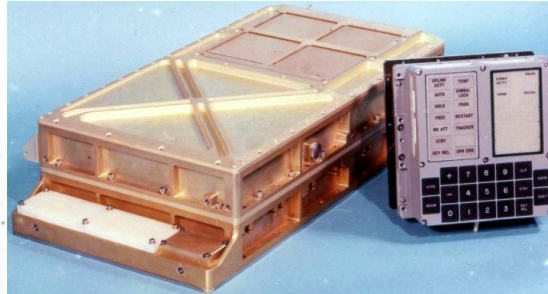

Fig. 2 Number of components per integrated function for minimum cost per component extrapolated vs. time.

IMPROVED RELIABILITY	
TOTAL	A G C RELIABILITY
COMPONENT	FABRICATION
Reliability now Equal to Transistor	(Same Process) Simpler Assembly and Test
More concentrated component product improvement	(Fewer Types) Reduced Number of Interconnecting Wires
Better Vendor Process Control	(Larger Volume) Only ONE WELD SCHEDULE
Better Fabrication Quality Assurance	(Fewer Types Larger Volume of each) Reduced No. of Unique Subassemblies
	Improved Simplified Mechanical Inspection
	Flow Chart
	Std. 960 Micro 670
	Flow Chart
	Std. 49 Micro 16
	Visual Std. Patterns

apollo M.I.T. INSTRUMENTATION LABORATORY 11/62

REDUCED COST	
TOTAL COST	
COMPONENT	FABRICATION
1. Cost Trend (chart)	1. Simpler Assy & Test (chart)
2. Competitive Sources (correspondence)	2. Reduce Scope of Q. A.
3. Volume Break Point (standard business)	3. Reduce Training & Documentation for: Fabrication Inspection Assembly Test
	4. Fewer Jigs, Fixtures & Test Equipment

apollo M.I.T. INSTRUMENTATION LABORATORY 11/62

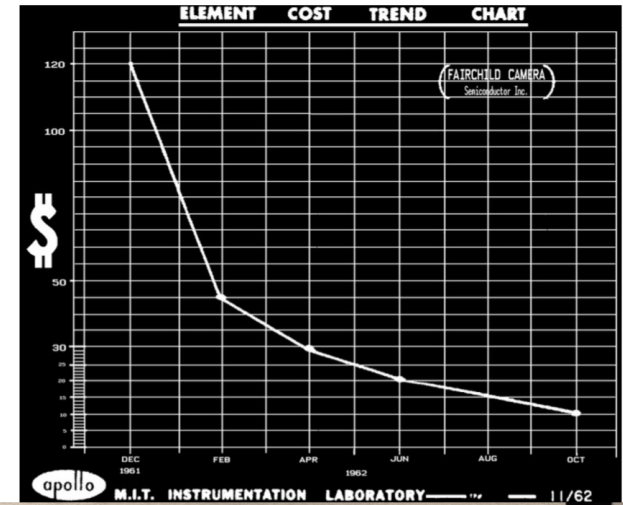

apollo M.I.T. INSTRUMENTATION LABORATORY 11/62

TRIPPLICATE PURCHASE ORDER

Massachusetts Institute of Technology
Cambridge 39 Massachusetts

11 137942

PAGE 1 of 2

REGISTRATION NUMBER Jan. 8, 1963

DATE MAILED: March 26, 1963

SHIP TO

TO: Texas Instruments, Inc.
31 Washington Street
Wellesley Hills 81, Massachusetts

66 Albany Street
H, Yop MS-166

SEE BELOW QUANTITY DESCRIPTION PRICE

1	4100	Micro Nor-Gate element	@ \$24.88 each	102,008.00
---	------	------------------------	----------------	------------

I SPECIFICATIONS

- In accordance with attached NASA Drawing #1006771 Rev. E.

II DELIVERY

- First 100 units to be delivered 12 weeks A.R.O.
- 1000 units 6 weeks after delivery 1 above.
- 500 units 1 week after 2 above.
- 750 units per week to completion of order.

III PRICE

Source: Gordon E. Moore, Cramming More Components onto Integrated Circuits, *Electronics*, pp. 114–117, April 19, 1965.

13 Generations of Apple Mobile System-on-Chips

Chip	A4	A5	A6	A7	A8	A9	A10	A11	A12	A13	A14	A15	A16
Year	2010	2011	2012	2013	2014	2015	2016	2017	2018	2019	2020	2021	2022
Device	iPhone 4	iPhone 4s	iPhone 5	iPhone 5s	iPhone 6	iPhone 6s	iPhone 7	iPhone 8 & X	iPhone Xs	iPhone 11	iPhone 12	iPhone 13	iPhone 14
Node	45nm Samsung	45nm Samsung	32nm Samsung	28nm Samsung	20nm TSMC	16nm TSMC	16nm TSMC	10nm TSMC	7nm TSMC	7nm TSMC	5nm TSMC	5nm TSMC	4nm TSMC
Area [cm ²]	0.52	1.25	0.96	1.03	0.89	1.05	1.25	0.88	0.83	0.98	0.88	1.08	1.14

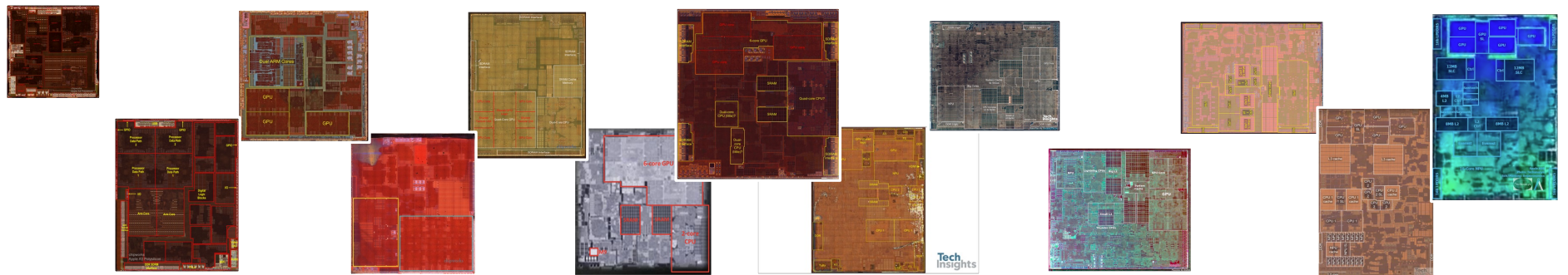

Die photos: chipworks/TechInsights/Angstometrics
Data source: wikipedia

2010

iPhone 4

45nm Samsung

A4 SoC

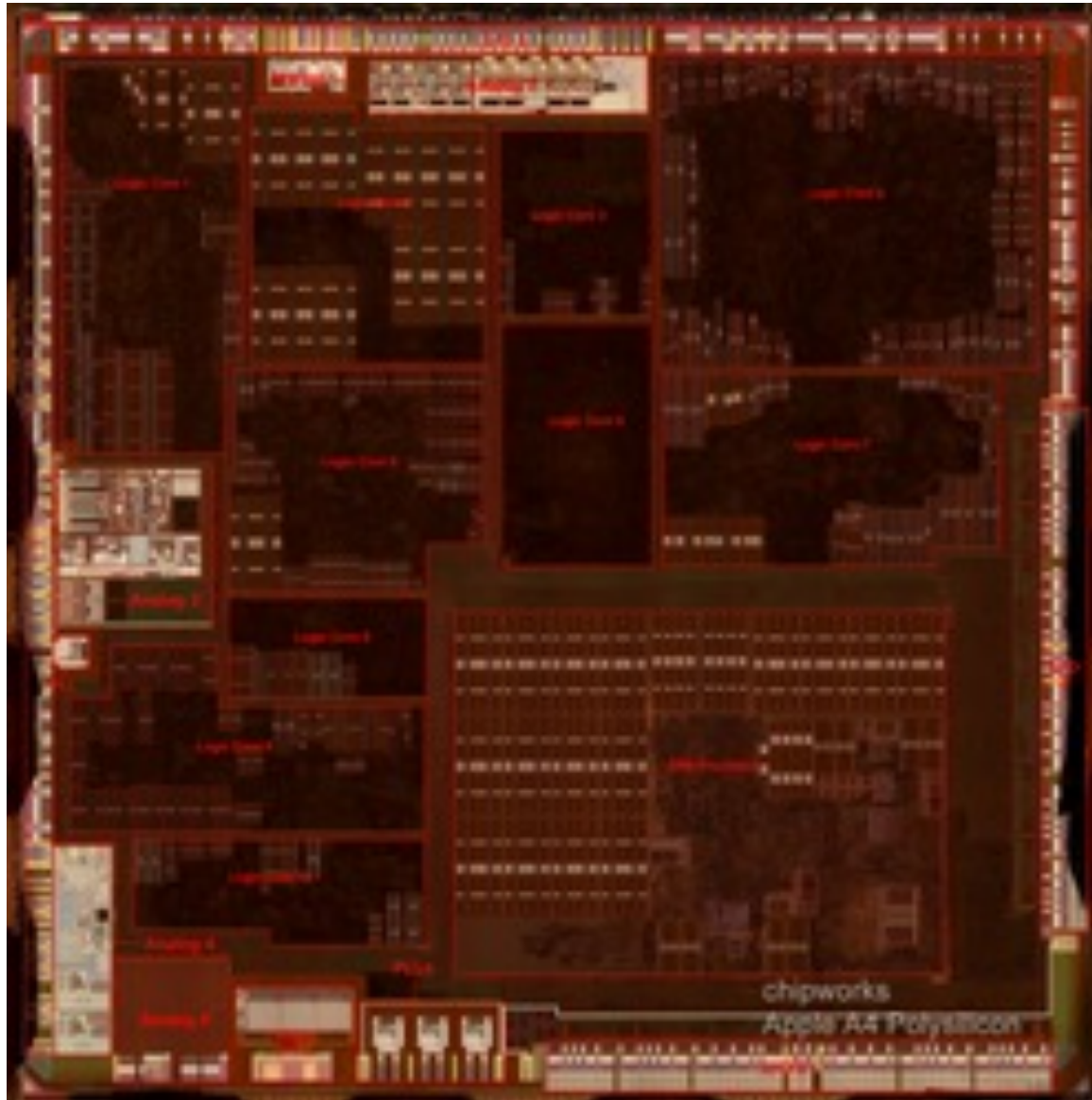

Die photos:
chipworks/TechInsights/Angstometrics
Data source: wikipedia

2011

iPhone 4s

45nm Samsung

A5 SoC

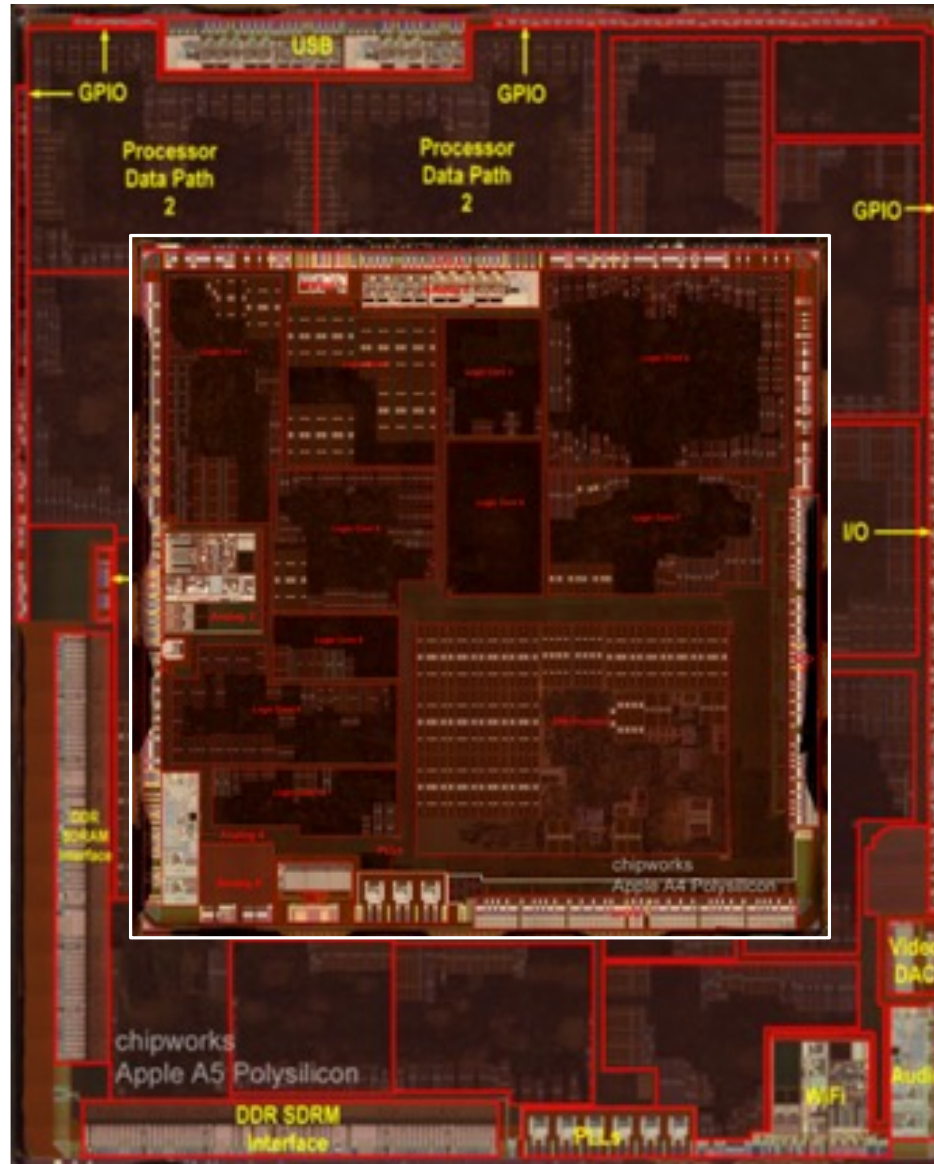

Die photos:
chipworks/TechInsights/Angstomiconics
Data source: wikipedia

2012

iPhone 5

32nm Samsung

A6 SoC

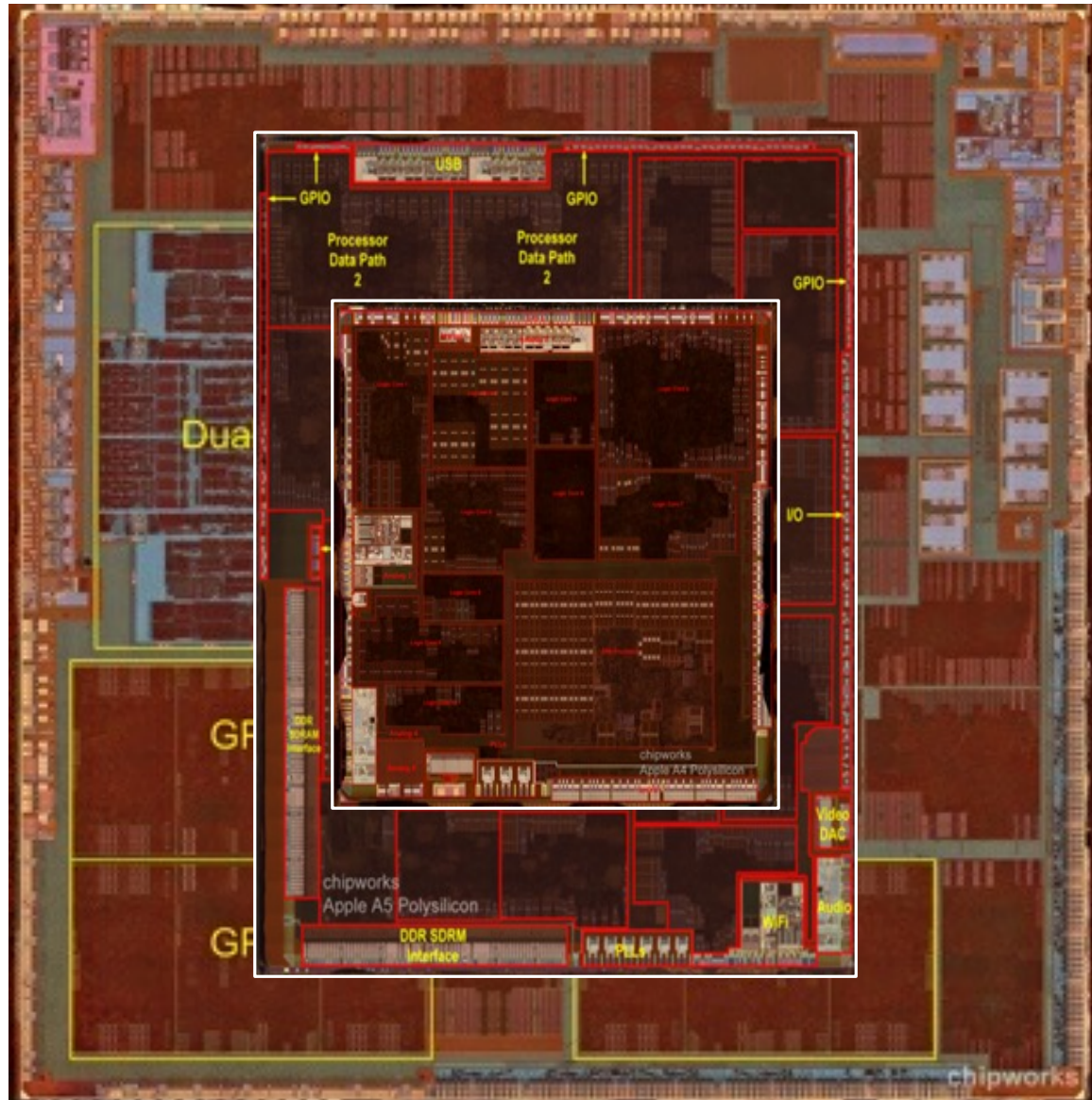

Die photos:
chipworks/TechInsights/Angstomiconics
Data source: wikipedia

2013

iPhone 5s

28nm Samsung

A7 SoC

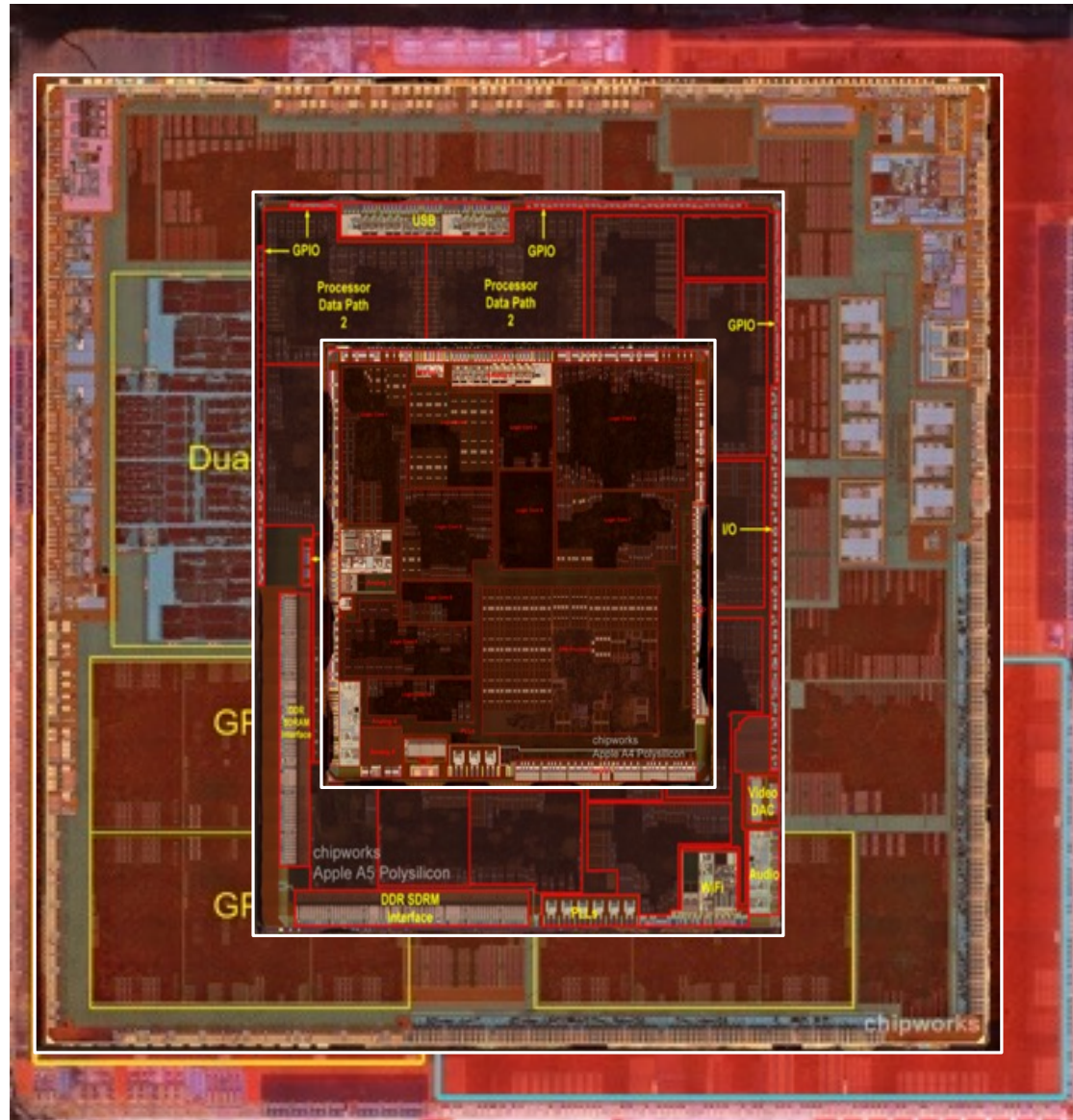

Die photos:
chipworks/TechInsights/Angstometrics
Data source: wikipedia

2014

iPhone 6

20nm TSMC

A8 SoC

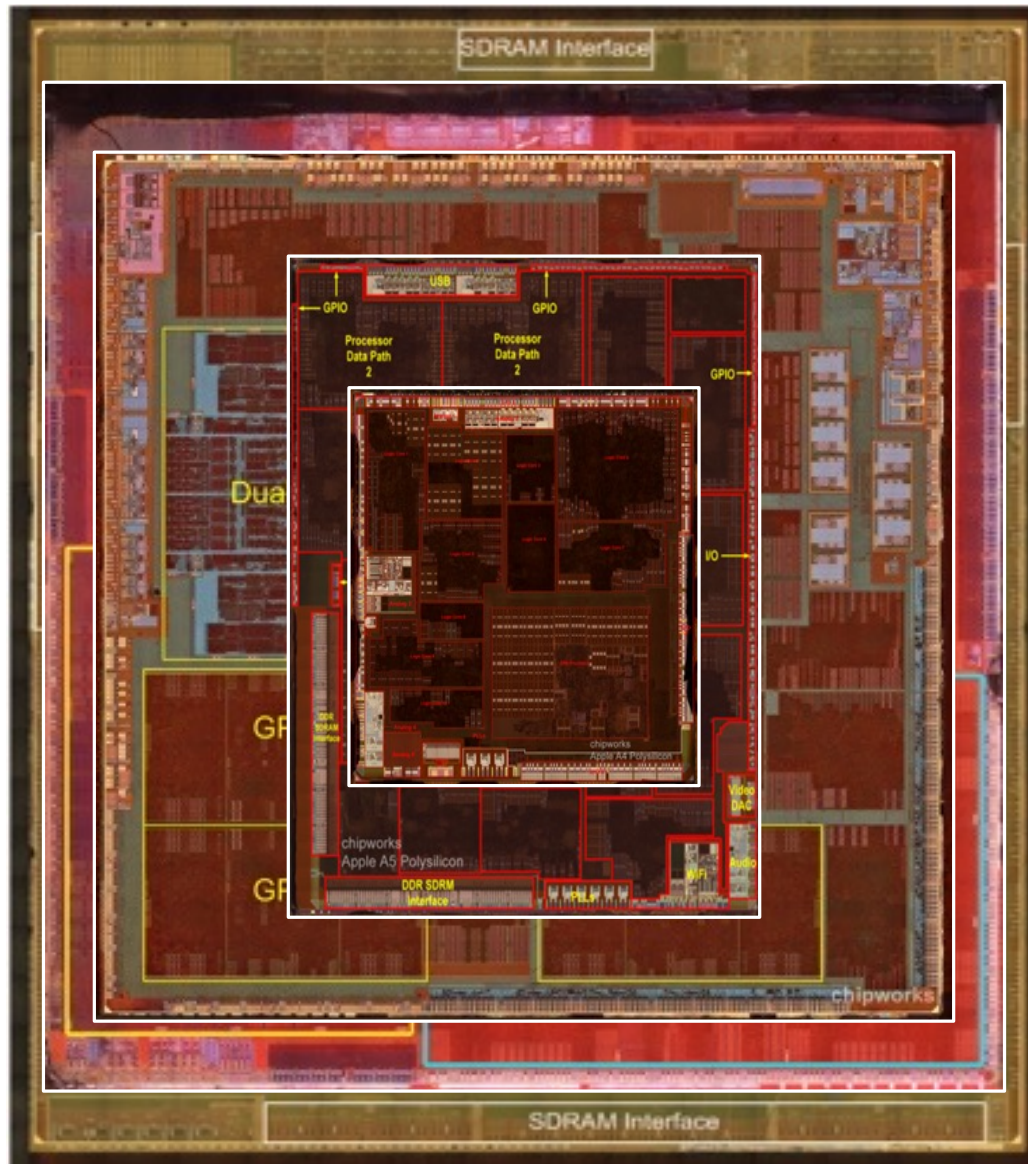

Die photos:
chipworks/TechInsights/Angstomiconics
Data source: wikipedia

2015

iPhone 6s

16nm TSMC

A9 SoC

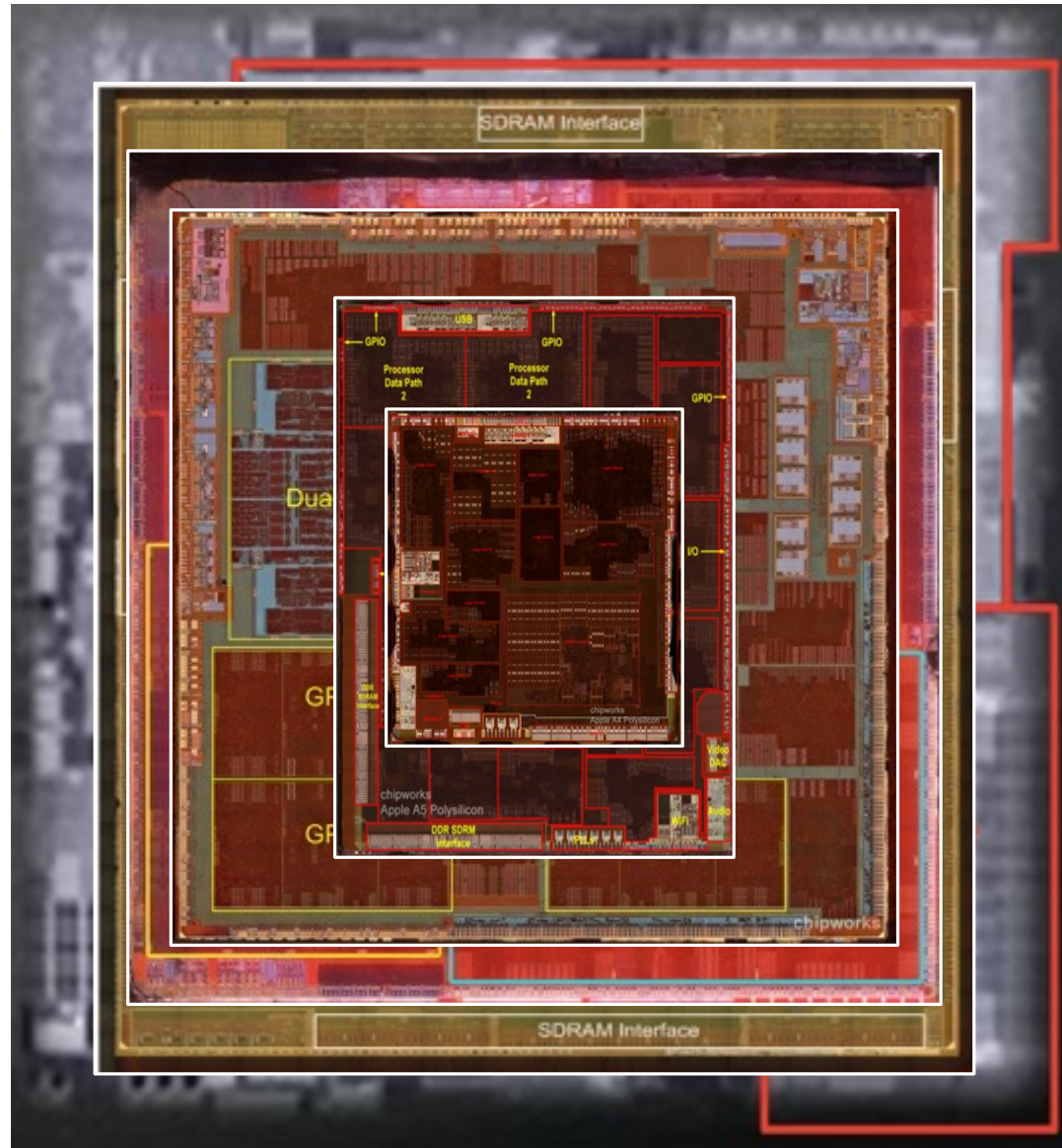

Die photos:
chipworks/TechInsights/Angstomiconics
Data source: wikipedia

2016

iPhone 7

16nm TSMC

A10 SoC

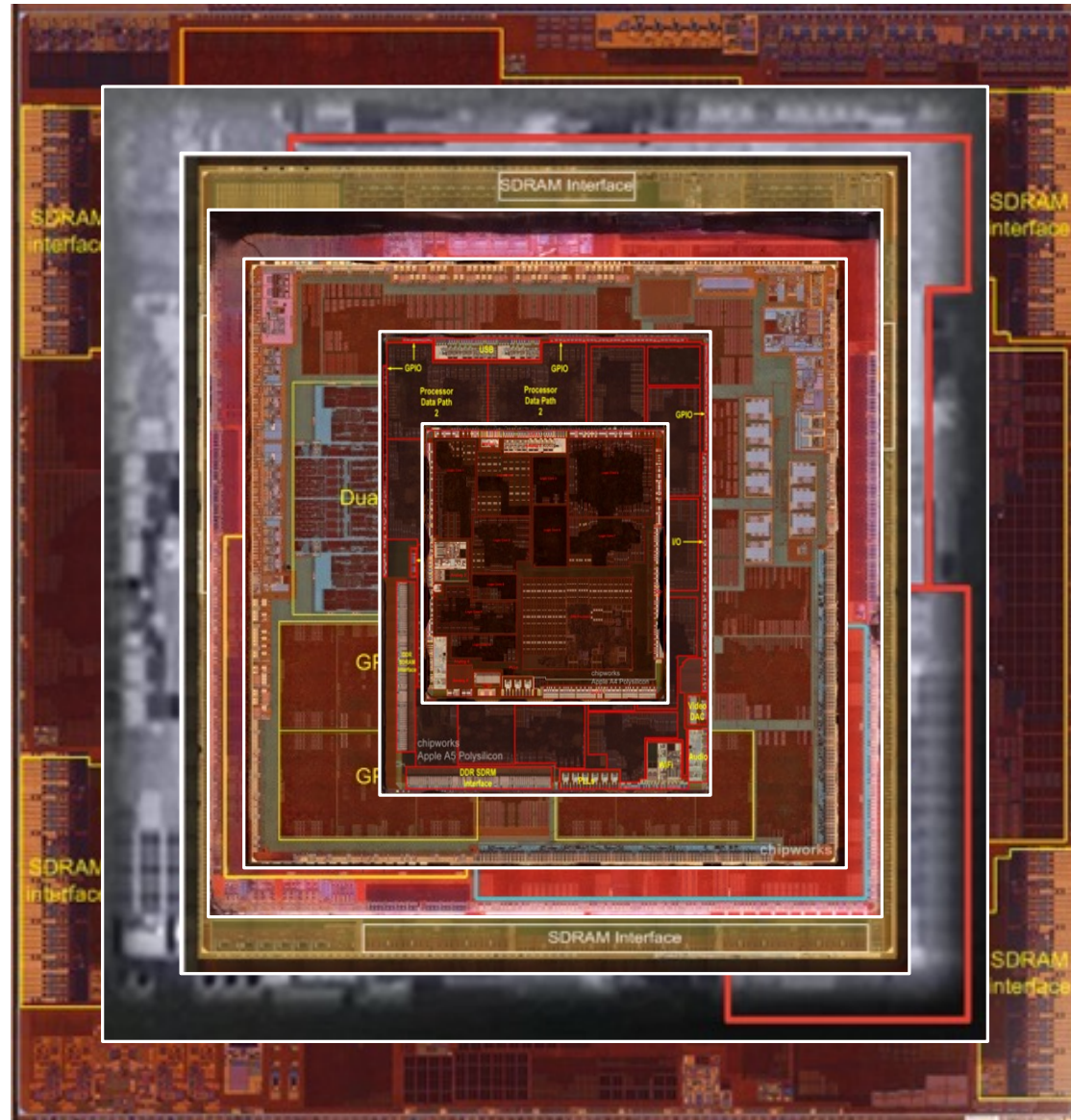

Die photos:
chipworks/TechInsights/Angstomiconics
Data source: wikipedia

2017

iPhone X & 8

10nm TSMC

A11 SoC

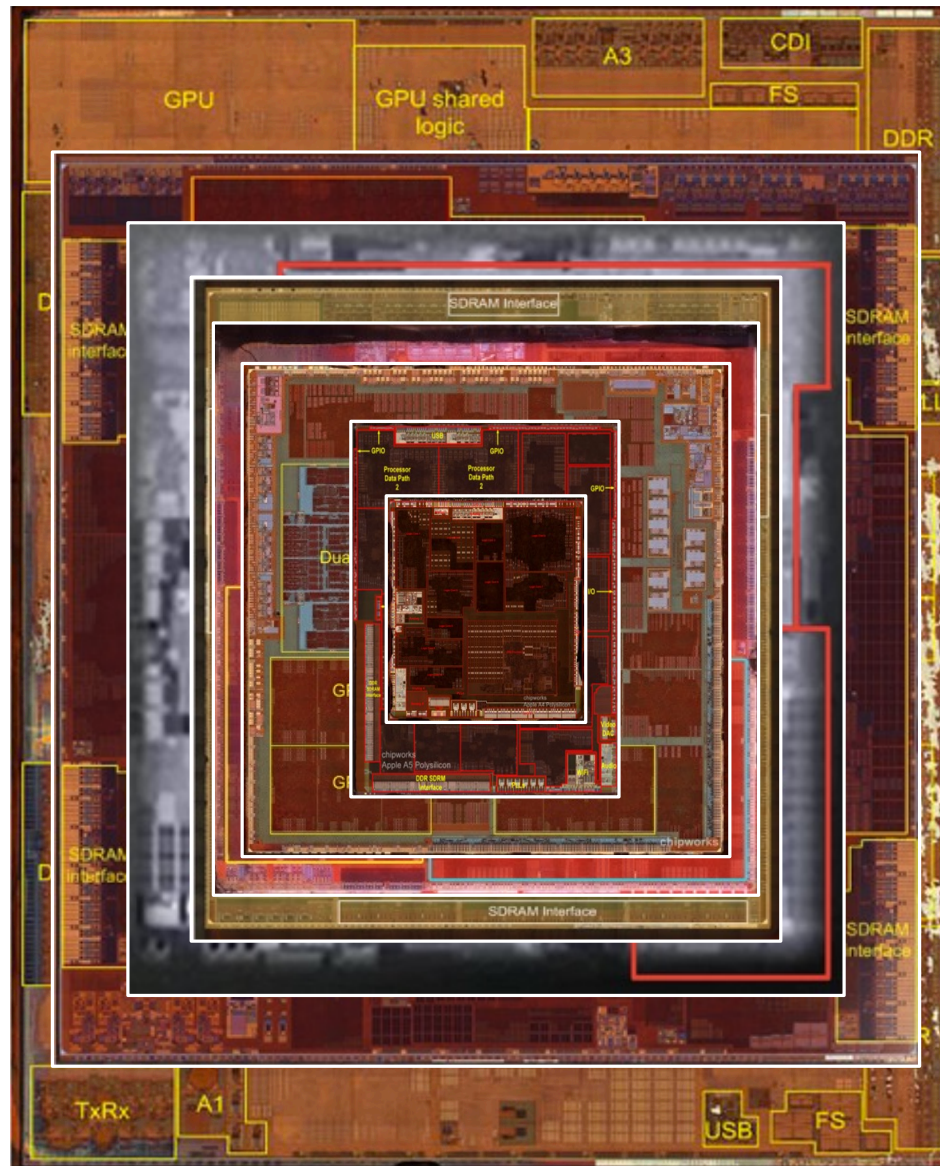

A11 SoC

Die photos:
chipworks/TechInsights/Angstomiconics
Data source: wikipedia

2018
iPhone Xs
'7'nm TSMC
A12 SoC

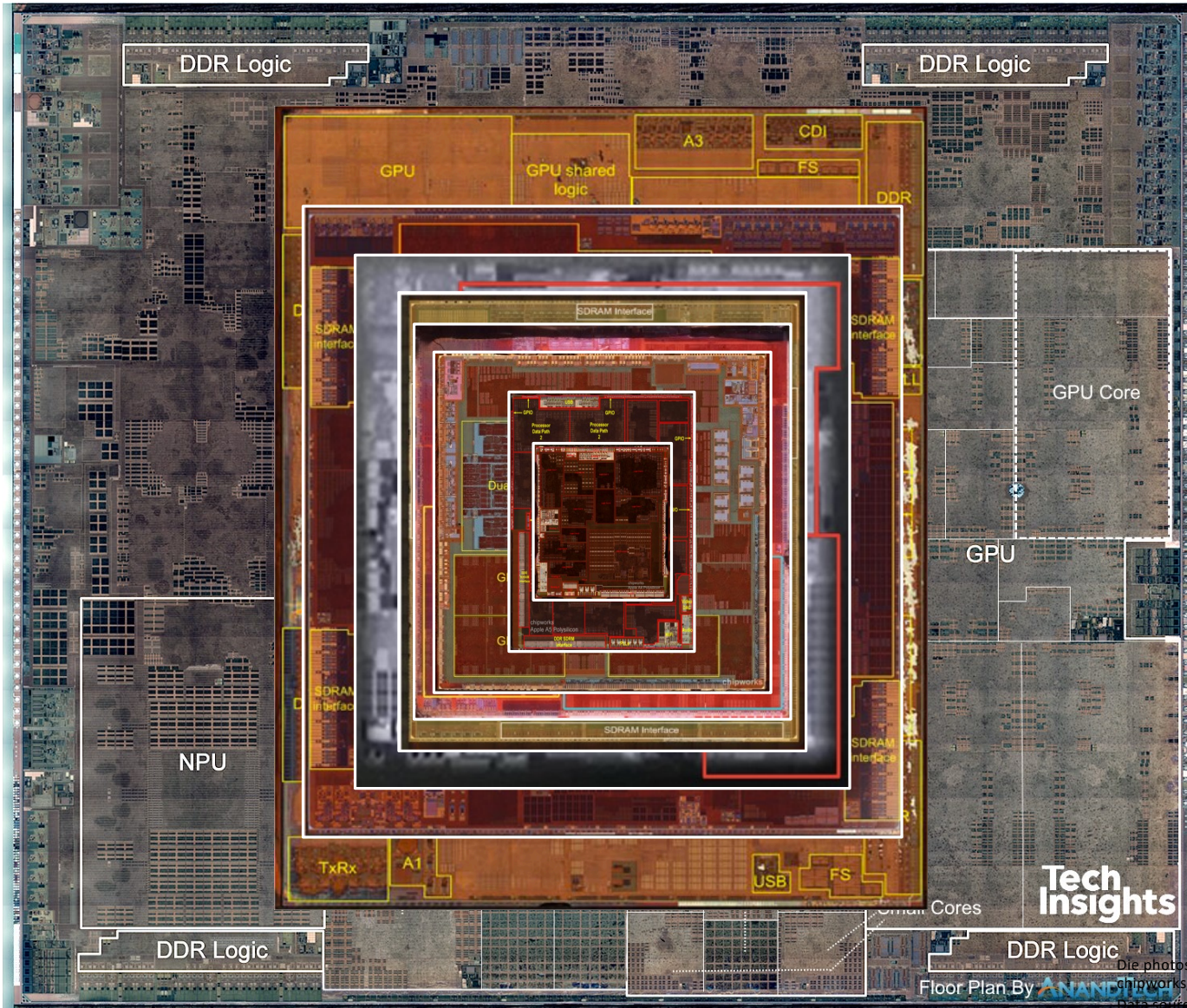

A12 SoC

Tech Insights
Die photos by chipworks, TechInsights/Angstomiconics
Floor Plan By ANANDSHRUTI
https://www.techinsights.com/2018/09/12/a12-die-photos/

2019
iPhone 11
7nm TSMC
A13 SoC

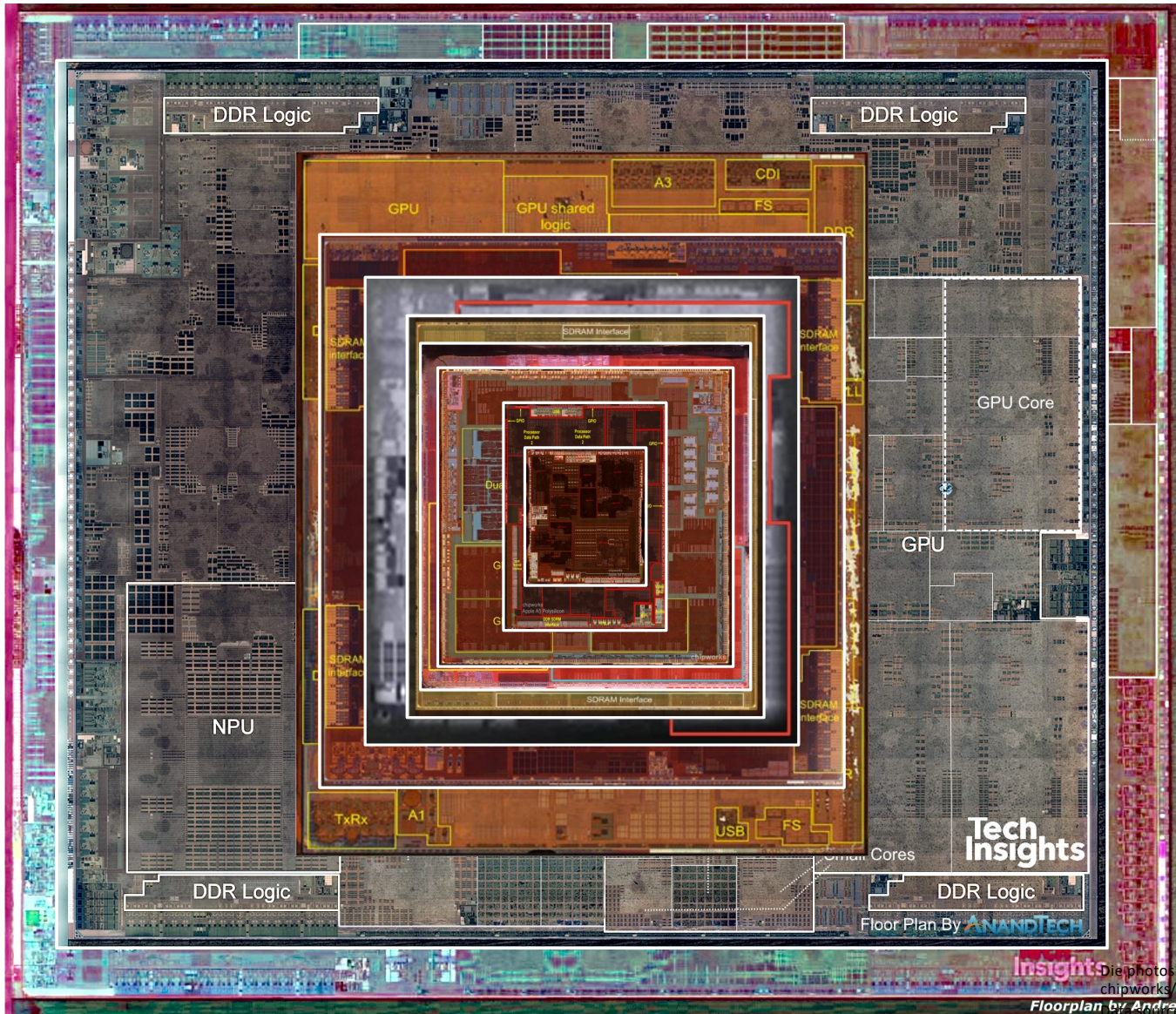

A13 SoC

Die photos:
chipworks/TechInsights/Angstometrics
Floorplan by Andrei wikipedia

2020

iPhone 12

5nm TSMC

A14 SoC

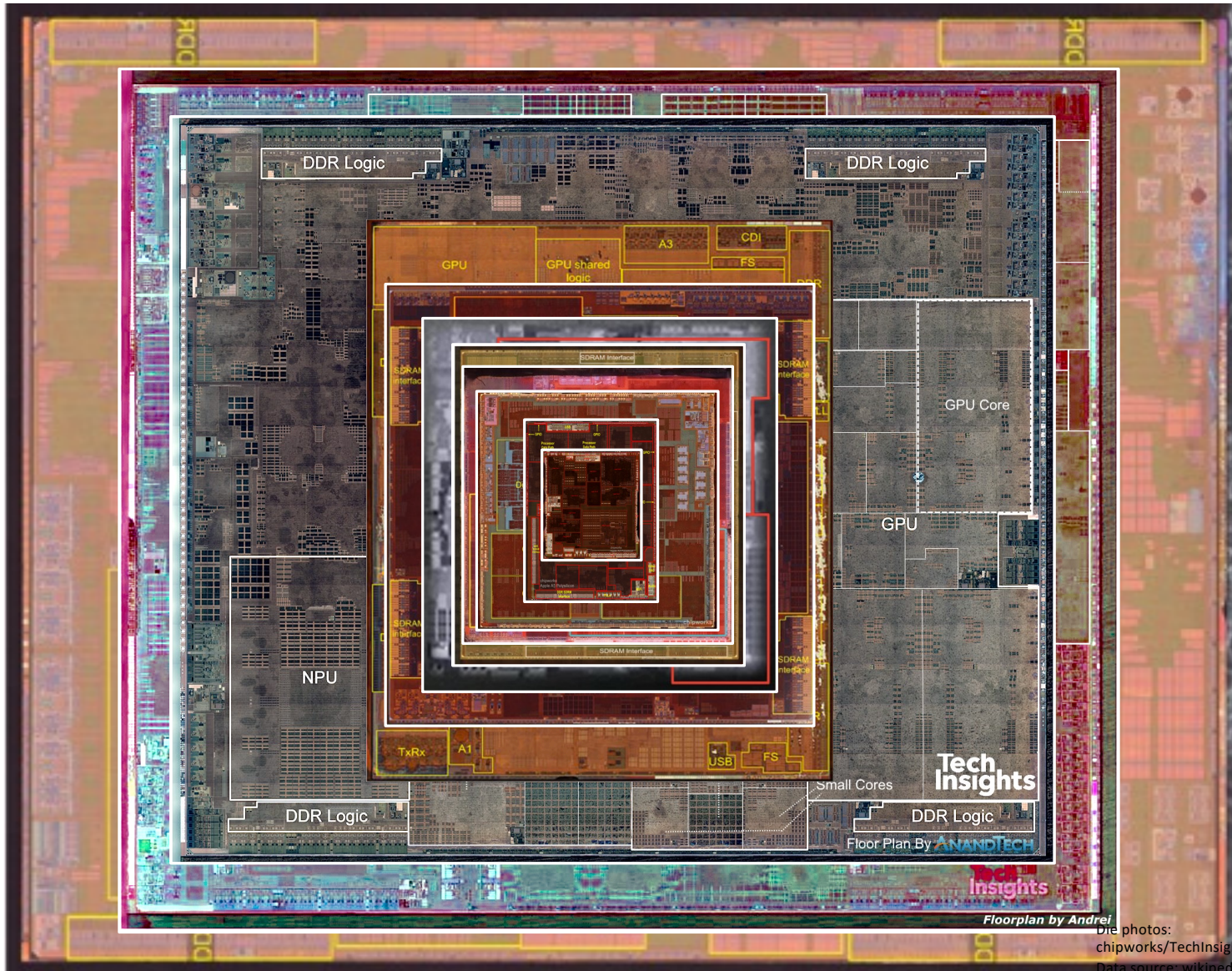

2022

iPhone 14

4nm TSMC

A16 SoC

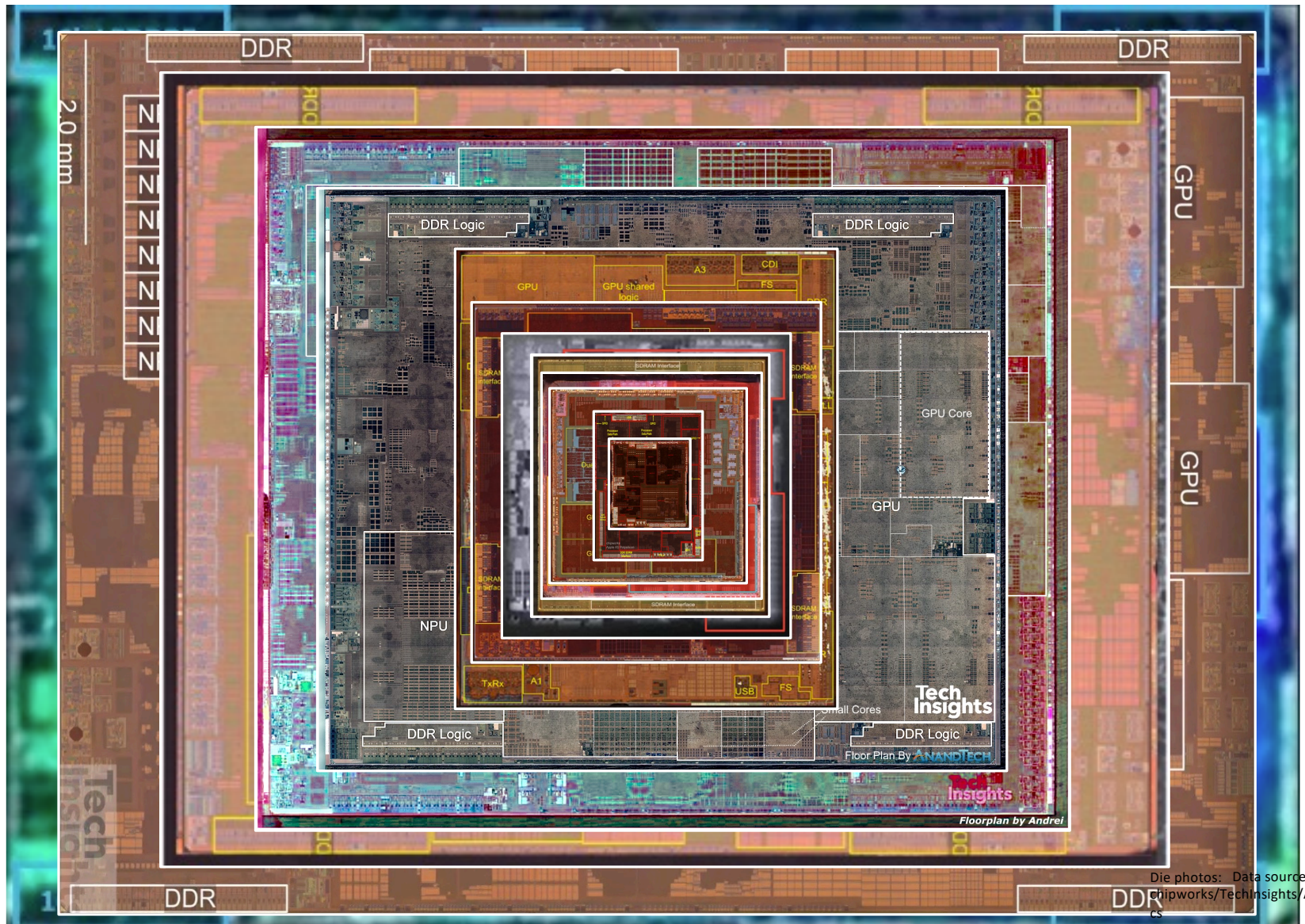

Die photos: Data source: wikipedia
Chipworks/TechInsights/Angstromi
cs

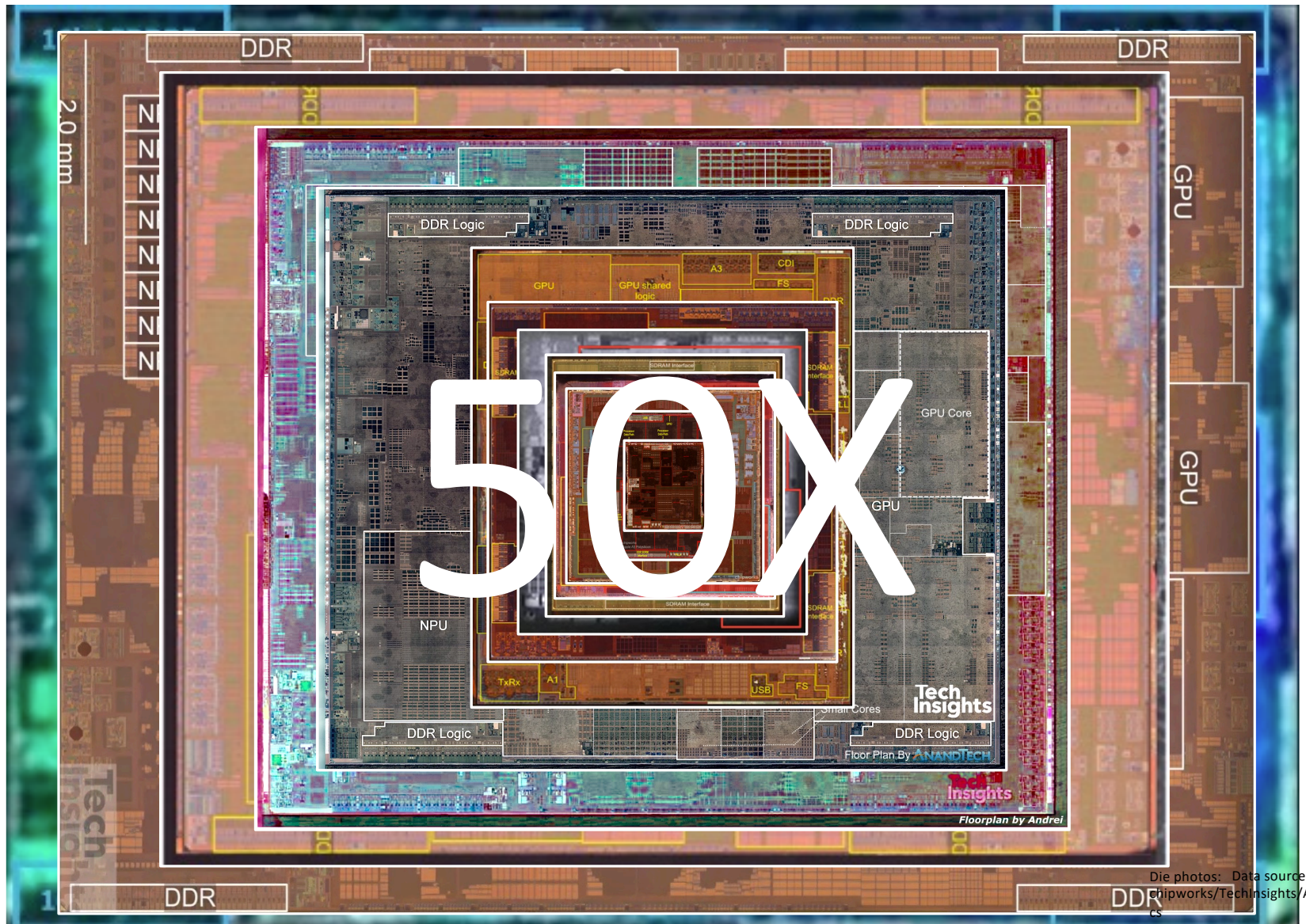

Die photos: Data source: wikipedia
chipworks/TechInsights/Angstromi
cs

Automotive Progress vs SoC Progress



1.2X

2010 2023

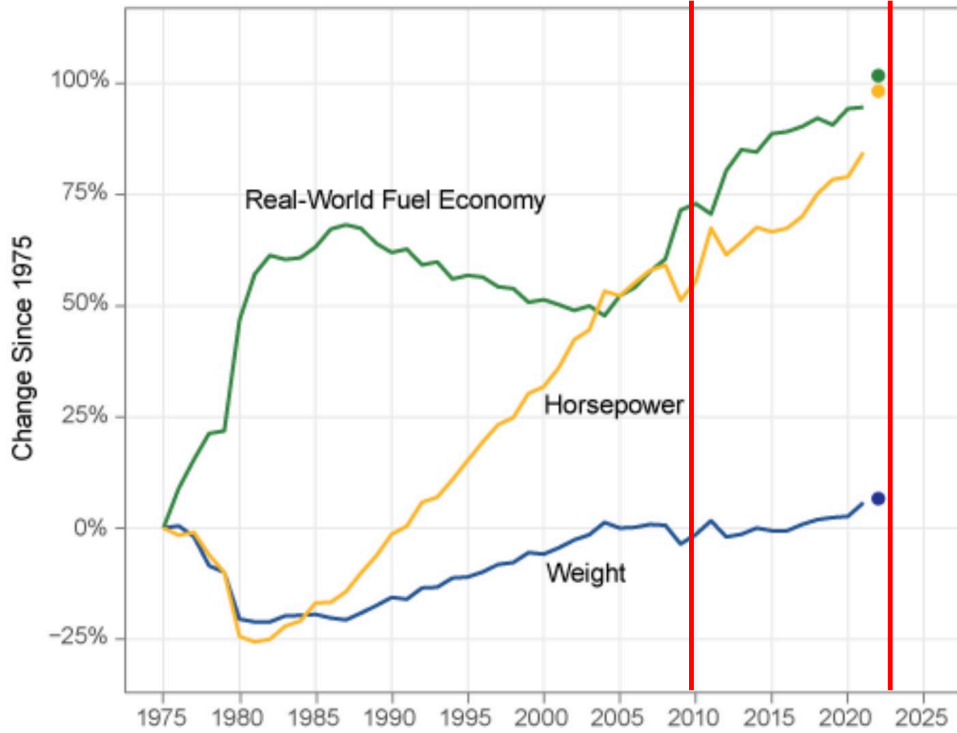

2010

50X



2023

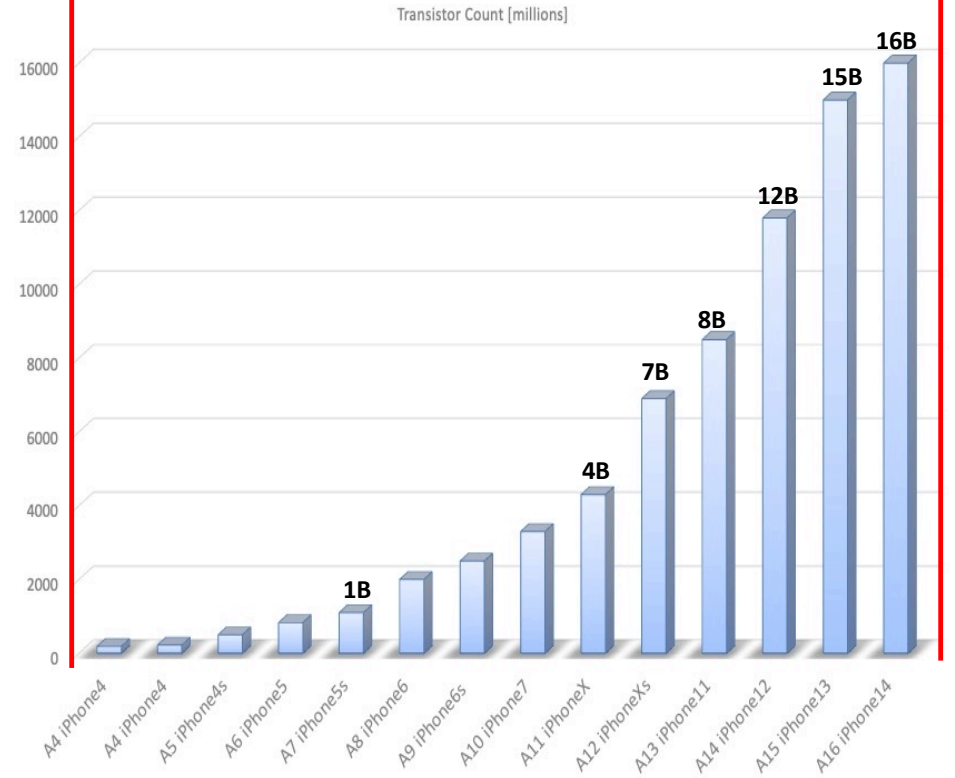

Claassen's Law

“The Perceived Usefulness of a new product is an underlying technology's logarithmic function”
Theo Claassen, Philips Semiconductor (now: NXP), 1999

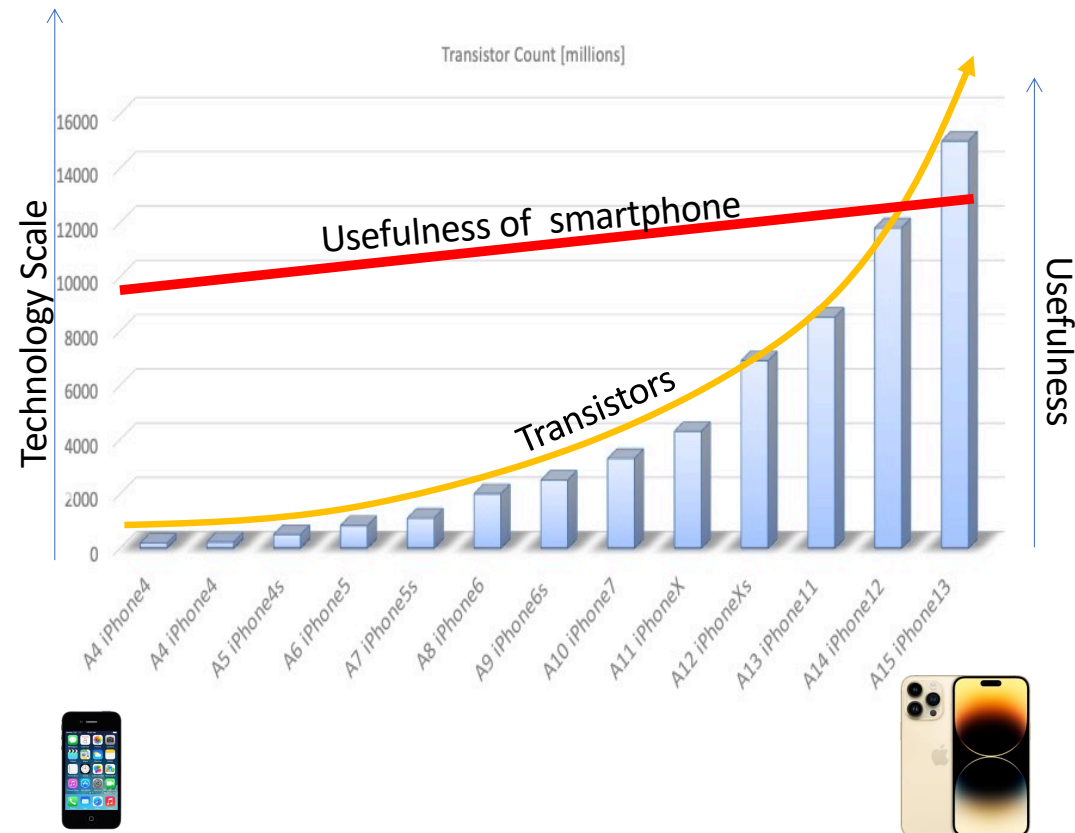

How was “Moore’s Dividend” Reinvested?

2012: A5 SoC (0.7B Transistors)

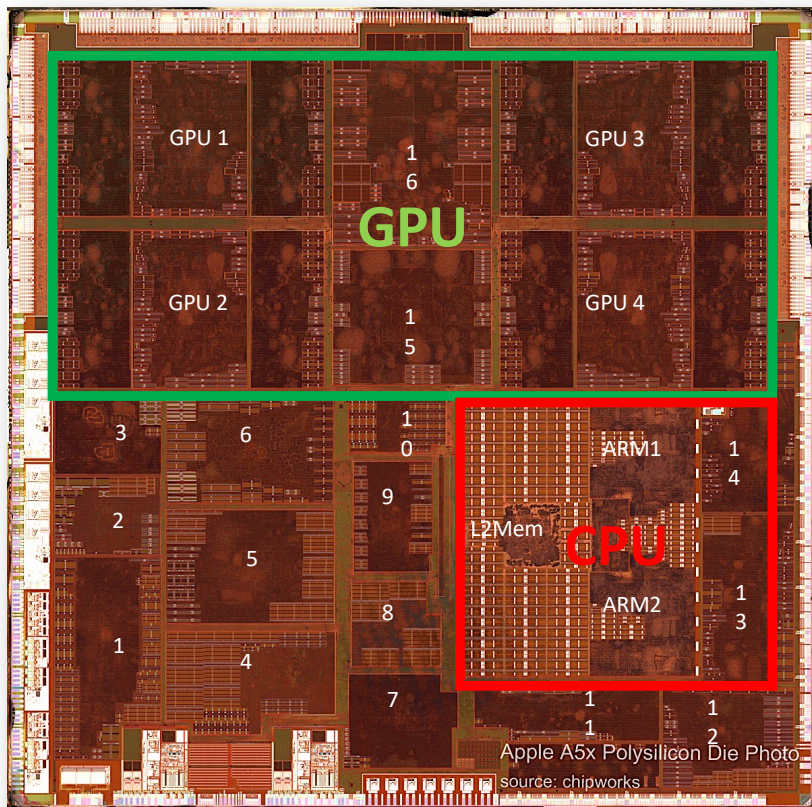

2018: A12 SoC (7B Transistors)

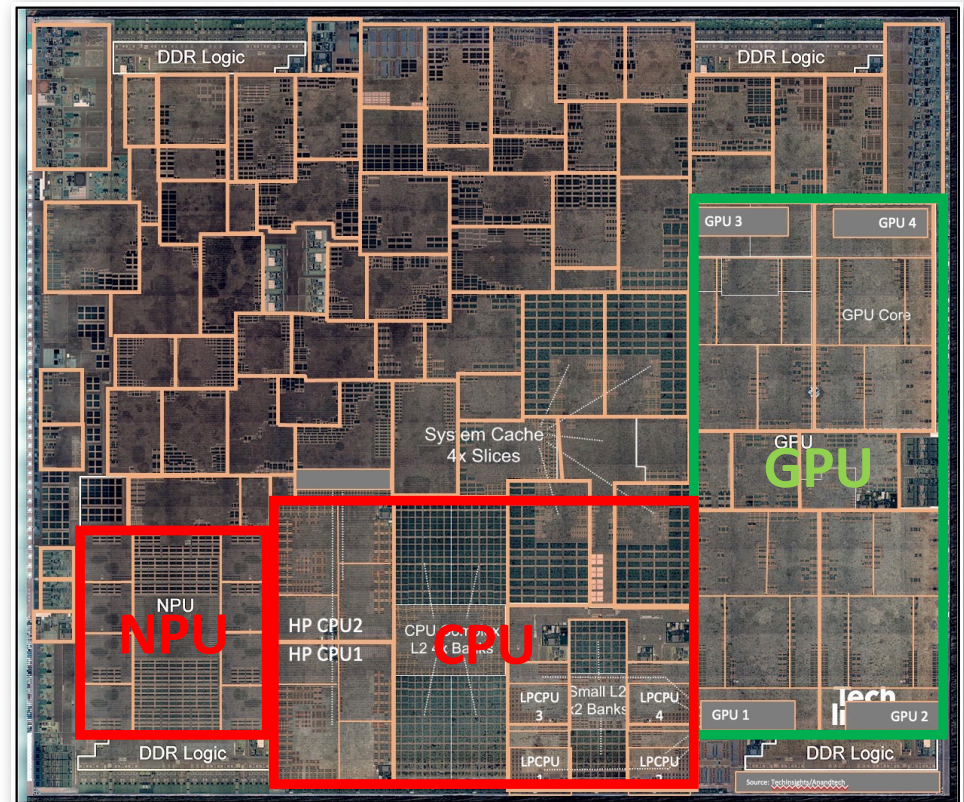

The Past 5 Years of Apple Mobile SoCs

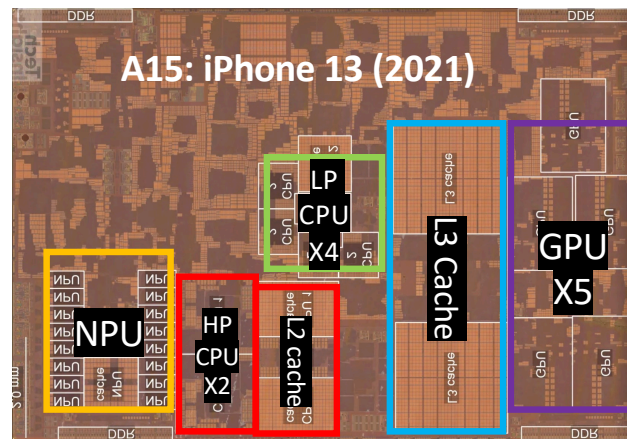
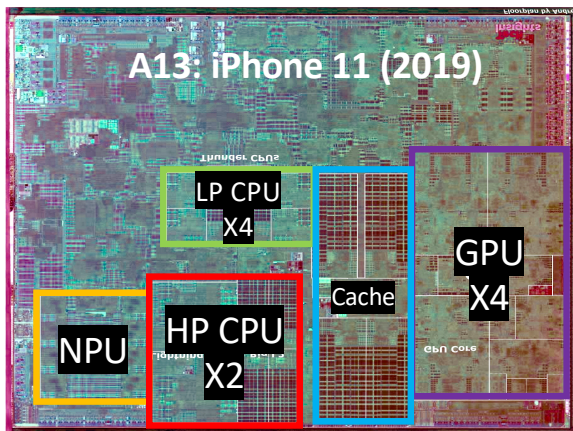
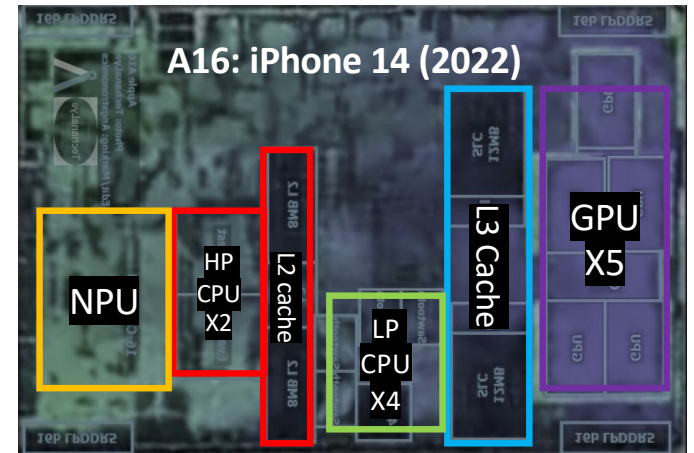
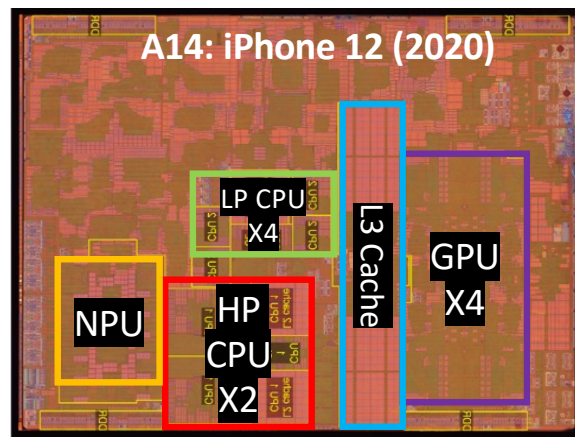
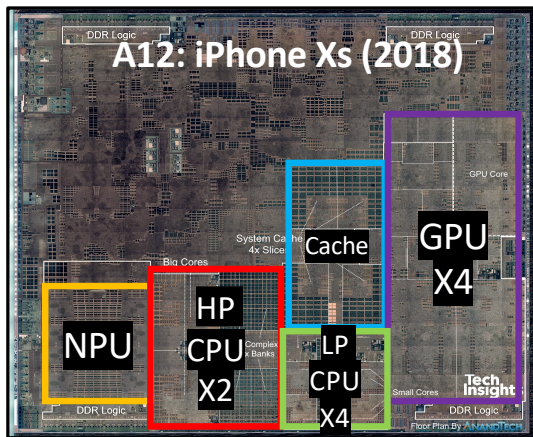

Imagine:
If The Wires On A 5nm Mobile SoC
Were As Wide As 2-lane Roads...

IC Wire pitch at 5nm: 28nm
2-lane Road width: 10m (30feet)
Scaling factor = 393Million

Scaled up, the wire is a road.
The **A16 Chip (iPhone 14)** contains:
~14 million miles wires in 10+ layers.
Connecting
~16 Billion transistors
~1.2 Billion standard cells
Consumes ~2 GigaWatt

The **USA** contains
2.7 million miles paved roads in 1 layer.
Connecting
0.31 Billion people
0.26 Billion cars
0.14 Billion homes
Consumes ~400 GigaWatt

2560miles/4100km

The World's Largest Chips in 2023

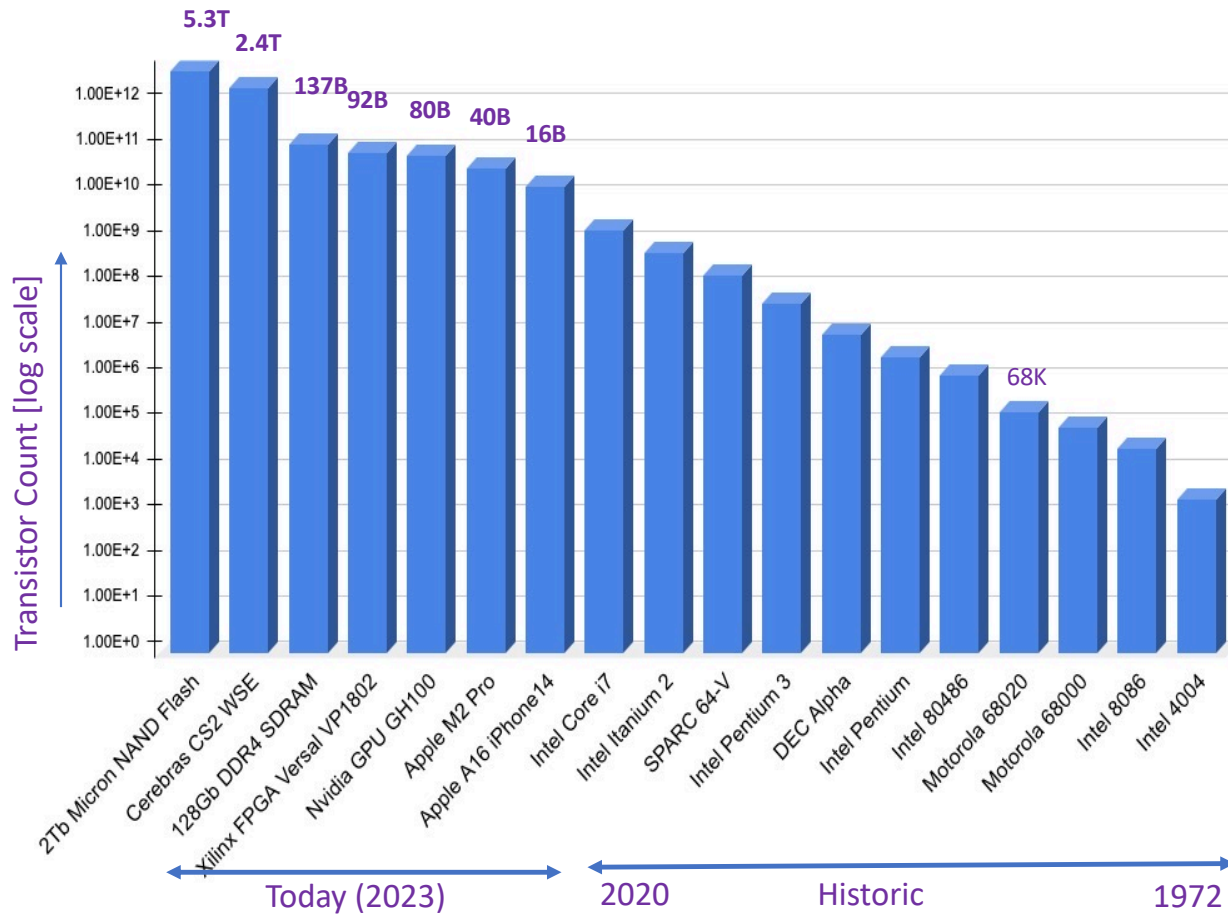

Micron's 232-layer NAND

The foundation for a new wave of end-to-end technology innovation

- Highest layer count
- Most bits/mm²
- Fastest I/O speed

Built on the proven technologies pioneered in Micron's industry-leading 176-layer NAND

Largest Flash: 5.3T

Generation	Density Gb/mm ²	Layers
1	~1	~20
2	~2	~40
3	~4	~80
4	~8	~160
5	~12	~200
6	~16	~232

Comparing the Scale of the Largest Chips

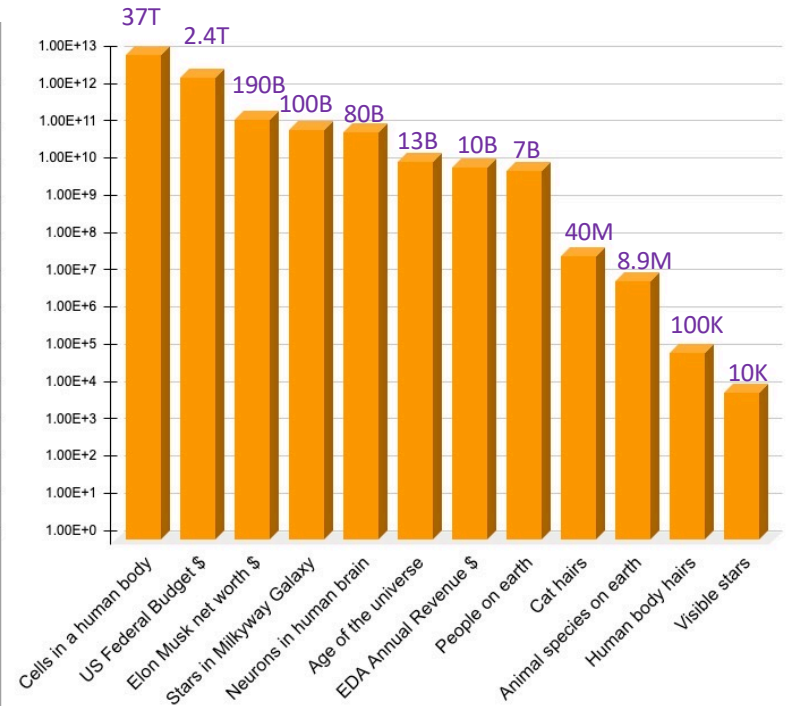
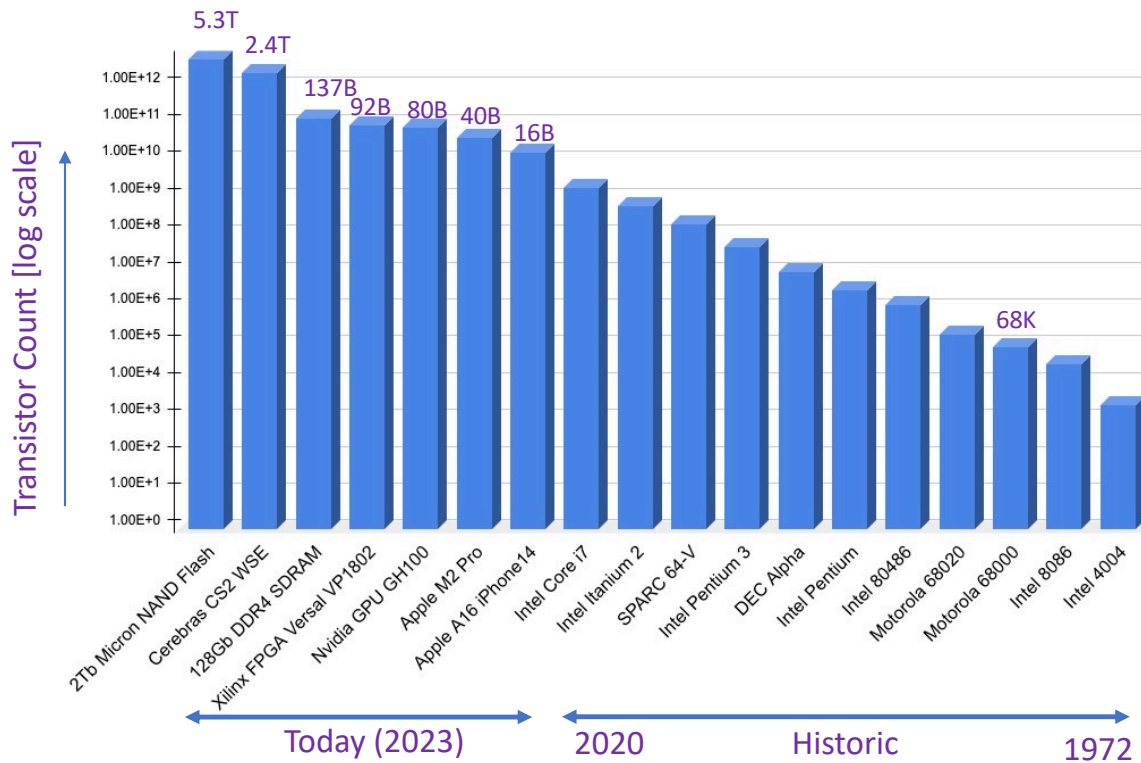

Human Cells vs Standard Cells

	Human Cell/human body	Standard Cell/chip
Cell Library size	200	200
Cell components	Nucleus, Ribosomes, membranes, DNA, Golgi, etc.	2-20 transistors, vias, wires
Number of cells	37,000,000,000,000	3,700,000,000
Main elements	C, H, O, N	Si, O, Cu
Design	Bottom-up evolution through natural selection, M-years	Top-down creation using EDA tools, months
(re-) production	Division, self-assembly	Lithography
Power	400W	400W
Infrastructure	Blood vessels, nerves	Power Wires, Clock network
MTBF/lifetime	8 years (cell) /80 years (person)	3 years (econ.)/ 10+ years
Error resilience	Self-healing	None
Failure mechanisms	Cancer, heart disease, infections	Electromigration, heat, ESD
Disposal	Self-composts	Landfill

Numerous as Sand on the Beach...



1000 BCE / Bible, Genesis 22 verse 17:
*I will surely bless you and make your descendants as numerous as **the stars in the sky** and as **the sand on the seashore***

1980 CE / Carl Sagan, Cosmos:
*There are **more stars in the universe** than there are **grains of sand on all the beaches of Earth***

2023 CE / Some dude on Twitter:
*There are **more transistors on earth** than **grains of sand on all the beaches of Earth***



Sand as a Parable for MOS Transistors

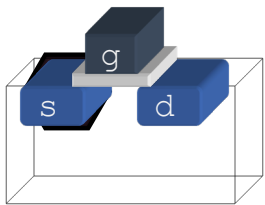
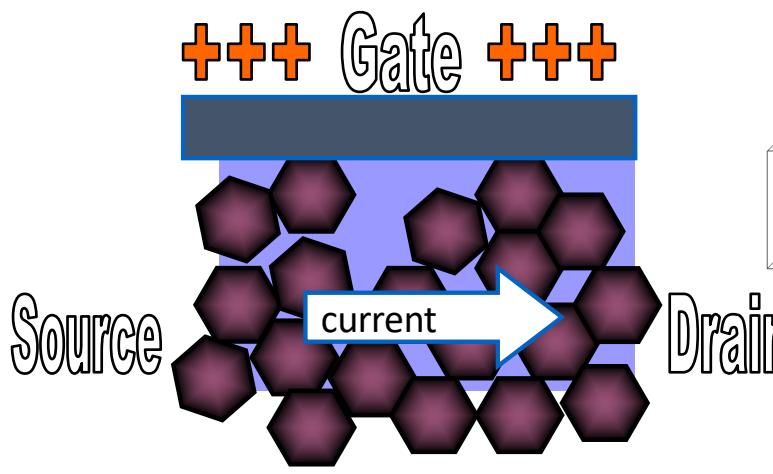
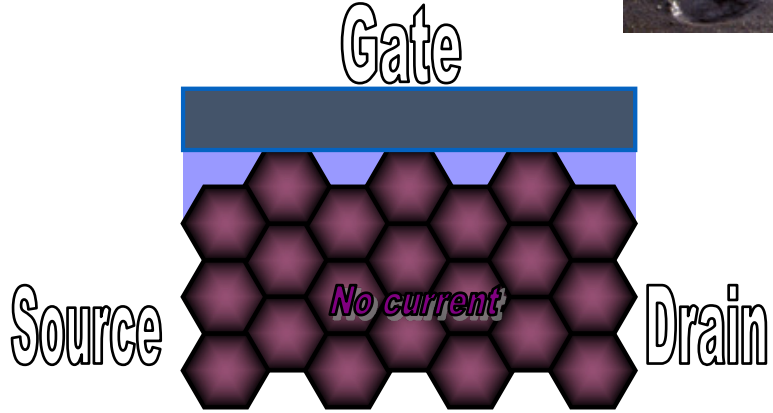
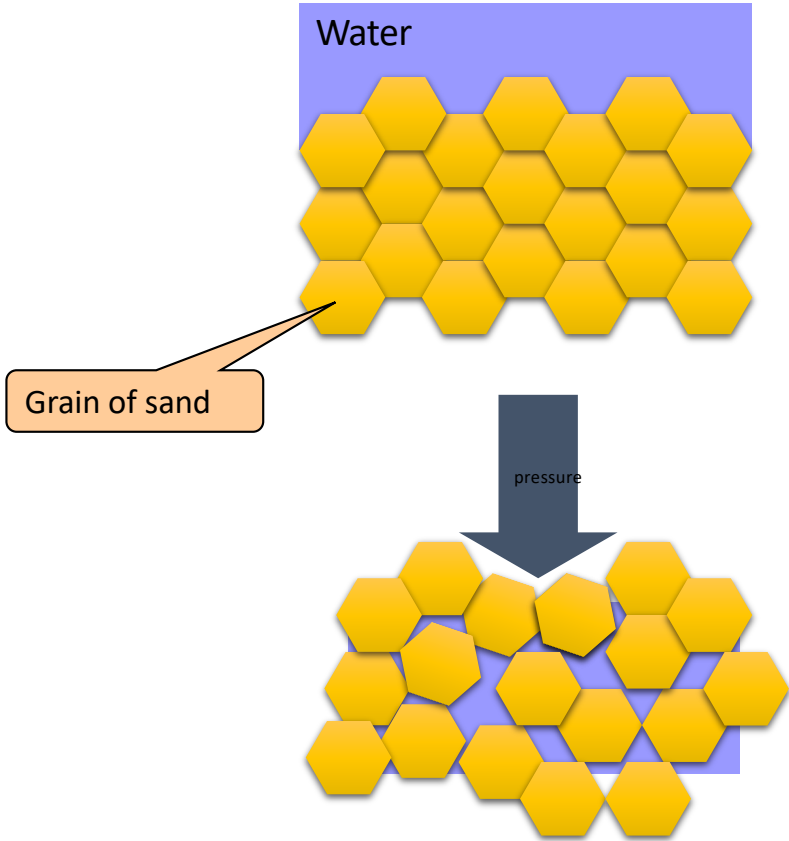

Beach Sand or Stars: Which is Greater?

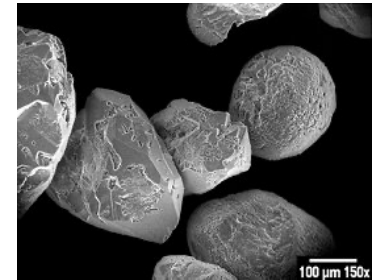

- There are $\sim 6 * 10^{21}$ (6 sextillion) grains of sand on beaches

- Sand is grains of mainly SiO_2 , typically 0.5mm diameter.
-> a cubic meter of sand contains $\sim 8B$ grains
- Assuming a beach is 200 meter wide and sand layer is 20 meters deep, then one km of beach has $1000 * 200 * 20 * 8B$ grains
= $3.2 * 10^{16}$ grains per km of beach.
- The world has 620,000 km of coastline, of which 31% is sandy
(Source: NASA)

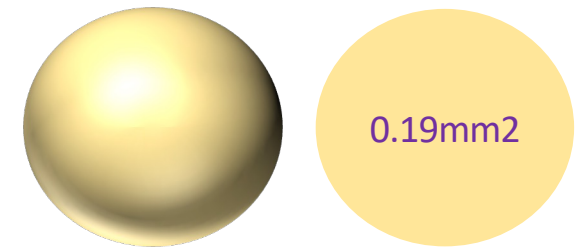

0.5mm

Room for
 $\sim 39,000,000$
Transistors in 5nm

- There are between 10^{22} and 10^{24} stars in the universe

- Between 10^{11} (100B) and 10^{12} (1T) stars per galaxy
- Between 10^{11} and 10^{12} galaxies in the universe (source: ESA)

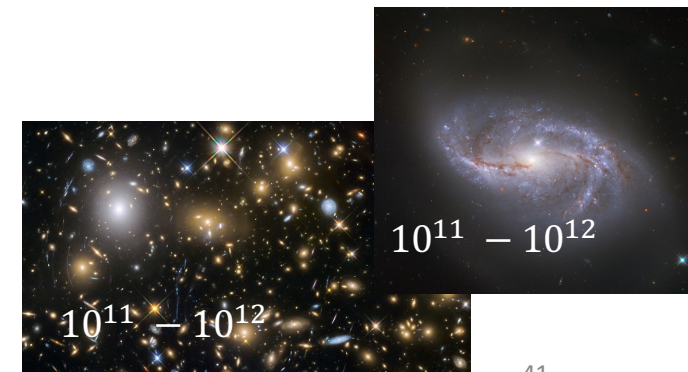

NASA/Hubble

How many Transistors are “Alive” in the World?

- Approx. $8 * 10^{19}$ in 2022 based on number of 12” wafers :
 - TSMC made 13M wafers, most in dense technologies of $\sim 3T$ transistors/wafer = $2.9 * 10^{19}$. They have $\sim 40\%$ of the market.
 - Approx. 72M raw 12-inch wafers were produced in 2022 @ $\sim 1T$ transistors per wafer
- Approx. $1.8 * 10^{21}$ in 2022 alone based on NAND FLASH memory market data:
 - Flash memory market was $\sim \$70B$ in 2022
 - at $\$100/\text{Terabyte}$ means that $\sim 700M$ TB were produced = $1.8 * 10^{21}$ Transistors (assuming $2.6 * 10^{12}$ transistors per TB = 6 bits per cell)
- With average product life of 3 years, we have $6 * 10^{21}$ transistors running, most of them as memory
- Conclusions:
 - There are approximately as many transistors as grains of sand on all beaches in the world
 - There are still more stars than transistors in the universe

Conclusion

- Semiconductor chips have reached astronomical scale, literally
 - Large enough to (almost) pass the Turing test
- EDA design methodologies still pull it off, somehow
 - Remember the “Design productivity gap”?
- The scale of electronics has amazing impact on society
- There are some downsides that we can - and should - manage:
 - Military, mass surveillance
 - Crypto

3900 Megawatt of installed Bitcoin mining in the USA alone.

- ~100 MWh energy per bitcoin
 - \$6K-\$10K power cost
 - 37,000,000kg CO2
- Running busywork on GPUs in dozens of data centers
- Bitcoin mining is approximately
 - ~1% of US generation
 - 1/3rd of all datacenters
- Bitcoin energy is equivalent to powering 7.8 Million electric cars.
 - = 3X more than all EVs in the USA

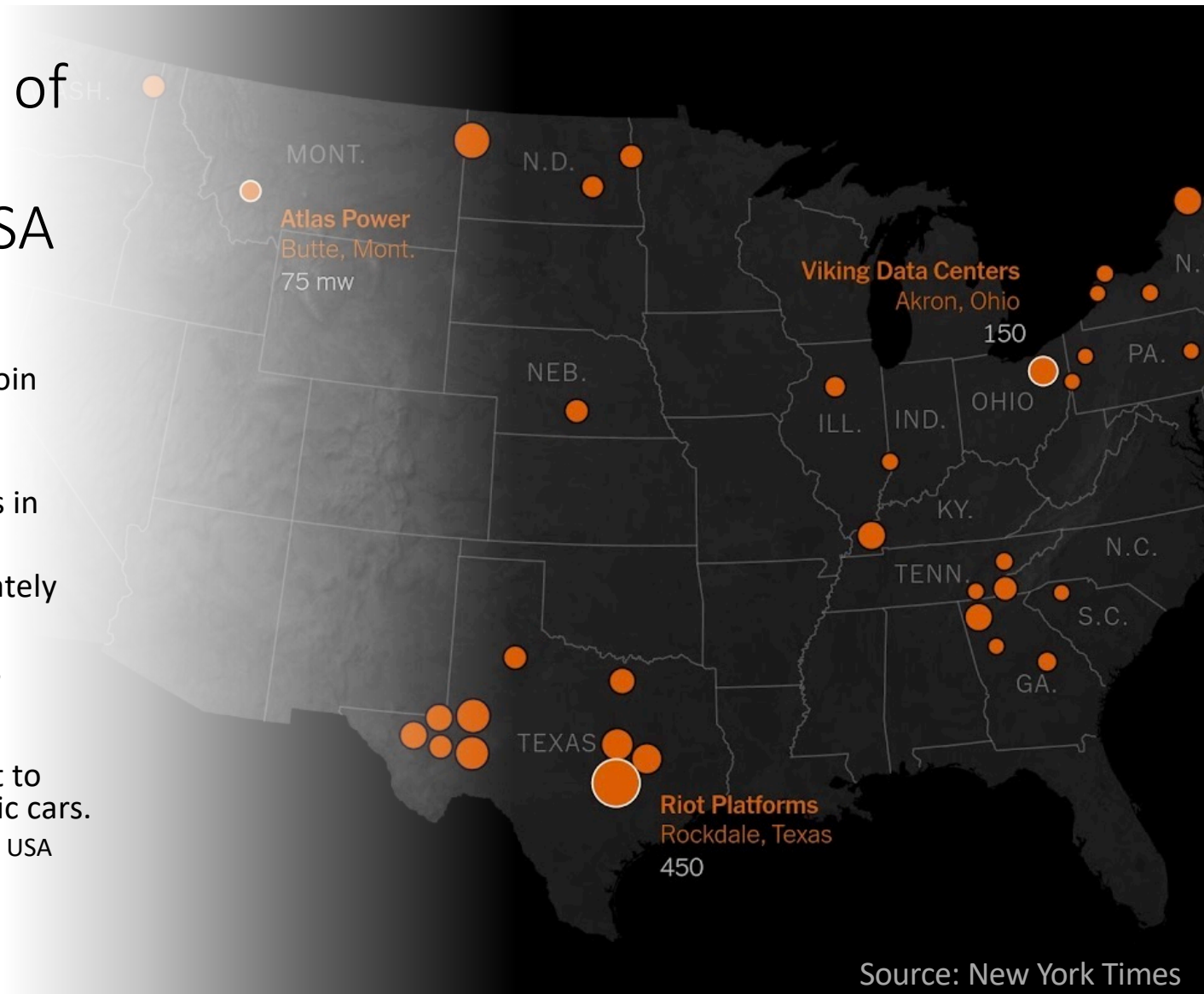

Source: New York Times